

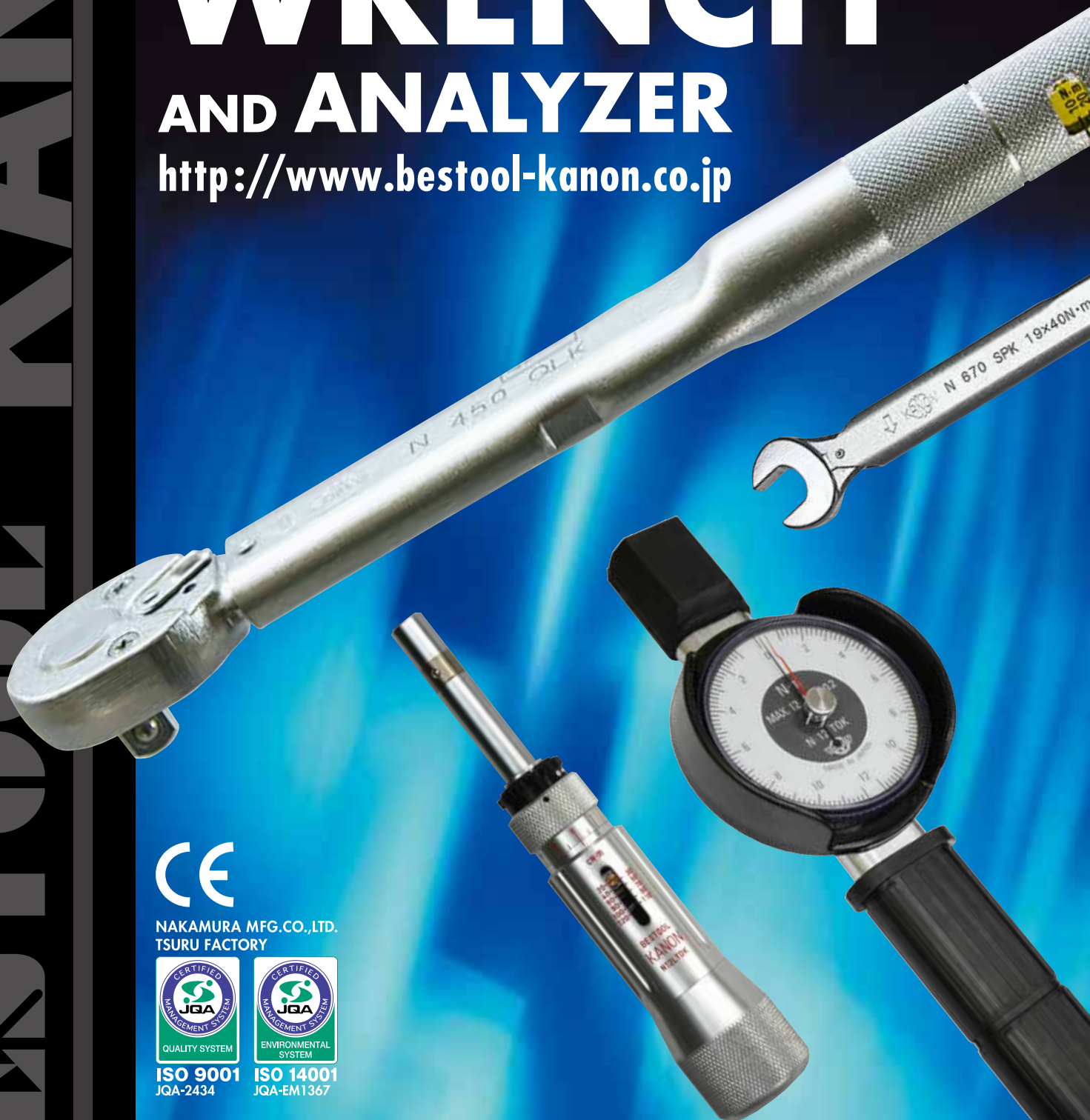

TORQUE WRENCH

AND ANALYZER

<http://www.bestool-kanon.co.jp>



NAKAMURA MFG.CO.,LTD.
TSURU FACTORY



ISO 9001
JQA-2434



ISO 14001
JQA-EM1367





Exploring the frontiers of higher accuracy and reliability.

Every single fastener fulfills an important function maintaining the life of every product. In the transportation or chemical industries, if a fastener loosens from improper tightening, it might cause a serious disaster costing human life. We focus our techniques and wisdom, accumulated over many years, on preventing such occurrences.

Tightening only by hand will cause unexpected disaster. For example,

Traffic accidents

Improper wheel nut tightening resulting in wheels coming off.

Construction accidents

Improper tightening of structural joints resulting in collapsing scaffolding or buildings.

Explosions

Improperly tightened underground gas line joints resulting in leakage and explosion.

Chemical accidents

In chemical plants, improperly tightened joints can release toxic substances.

Torque tools play an important role in preventing such incidents.

Torque tools tighten joints uniformly with adequate force.

In particular they serve:

1. To prevent under-or-over-tightening.
2. To tighten multiple bolts uniformly.
3. To adequately generate the clamping force required for bolted joints.

BESTOOL - KANON



PAGE 3
SPK
 PRE-SET
 TORQUE WRENCHES

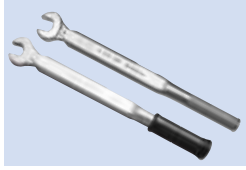

PAGE 4
RSPK
 PRE-SET, RING
 TORQUE WRENCHES

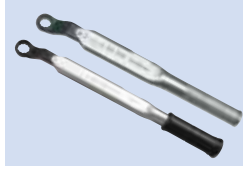

PAGE 5
QLK
 ADJUSTABLE, RATCHET
 TORQUE WRENCHES



PAGE 6
GLK/BLK
 ADJUSTABLE, RATCHET TORQUE
 WRENCHES WITH PLASTIC GRIP



PAGE 7
QSPK
QSPKH, QSPK-A

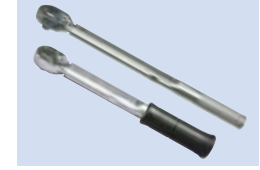

PAGE 8
SPCK/SPCKH
 PRE-SET, REPLACEABLE HEAD
 TORQUE WRENCHES

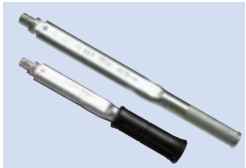

PAGE 9
LCK/GCK
 ADJUSTABLE, REPLACEABLE
 HEAD TORQUE WRENCHES

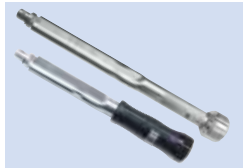

PAGE 10~12
HEADS
 OPTIONAL REPLACEABLE
 HEADS

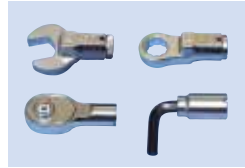

PAGE 12
ZLK
 KANON INSULATED ADJUSTABLE
 TYPE TORQUE WRENCH



PAGE 13
**QLK-LR/
 HYK**

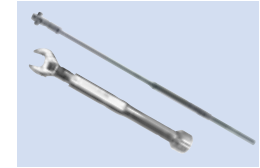

PAGE 14
DLT-N
 KANON DIGITAL TORQUE
 WRENCH

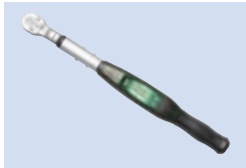

PAGE 15
FK
 INDICATOR PLATE
 TORQUE WRENCHES

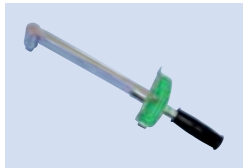

PAGE 16
TOK-G
 DIAL INDICATOR
 TORQUE WRENCHES



PAGE 17
LTDK
 CLUTCH RELEASE TORQUE
 SCREW DRIVERS



PAGE 18
STDK
 PRE-SET TORQUE DRIVERS



PAGE 19
DPSK
 DIAL GAUGE
 TORQUE DRIVERS

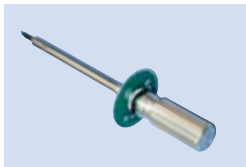

PAGE 20
SGK
 TORQUE GAUGES



PAGE 21
KDTA-SV
 DIGITAL TORQUE ANALYZERS



PAGE 22
KDTA-SVH
 LARGE DIGITAL TORQUE
 ANALYZERS



PAGE 22
TPK-3
 STANDARD PRINTER



PAGE 23~24
DRT
 KANON TORQUE MEASUREMENT
 MULTI-INDICATOR



PAGE 24
KDTA-svs
 DIGITAL TORQUE ANALYZERS



PAGE 25
KDTA-DH
 DIGITAL TORQUE ANALYZERS
 FOR TORQUE DRIVERS



PAGE 25
KDTA-D
 DIGITAL TORQUE ANALYZERS
 FOR ELECTRIC DRIVERS



PAGE 26
**MLK
 MQLK-E**

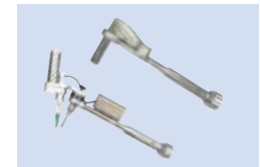

PAGE 27
**TCSK-99MA
 SWPM Series**



PAGE 28
TK
 TENSION GAUGES



PAGE 29
DTC-REV
 DATA OUTPUT DIGITAL TORQUE
 WRENCHES

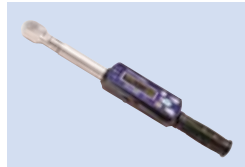

PAGE 30
DTDK-REV
 DIGITAL TORQUE DRIVER
 WITH CONNECTED DISPLAY



PAGE 30
DTC-REV
 DIGITAL TORQUE WRENCH
 WITH CONNECTED DISPLAY



SPK PRE-SET TORQUE WRENCHES

Audible and tangible "CLICK" when the set torque is reached, assuring a securely tightened joint. This series is well-suited for production line use.

FEATURES

- A single function wrench, used for a single setting combination of fastener size and torque setting.
- Most suited for tightening multiple same-size fasteners at the same torque in a production line.
- Setting confirmation unnecessary.
- Can be used effectively in confined spaces.
- Tightening to set torque only in the direction of the arrow indicator, but can be used for general tightening in the other direction as well.
- Accuracy : ±3% of pre-set value

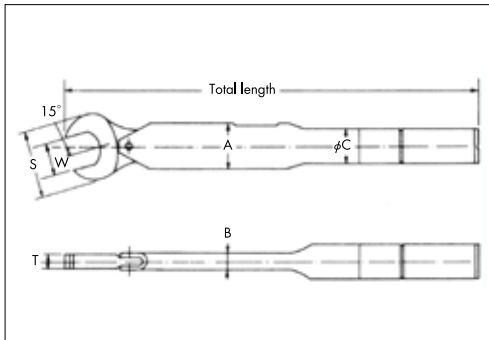

EXAMPLE OF ORDER

Model Size(W) Pre-set Value
 | | |
 N190SPK 10 × 14N·m

Model (kgf·cm)	Range (kgf·cm)	Old Model (N·m)	New Model (N·m)	Range (N·m)	Spanner sizes (W)								Total length (mm)	Dimensions (mm)					Weight (kg)					
					mm									Head		Body								
					5.5	6	7	8	9	10	11	12		13	S	T	A	B		C				
30SPK	5~30	N30SPK	N3SPK	0.5~3	5.5	6	7	8	9	10				152	24	5	19.5	7.5	15	0.1				
80SPK	15~80	N80SPK	N8SPK	1.5~8	5.5	6	7	8	9	10	11	12	13	175	24	5	19.5	7.5	15	0.11				
190SPK	35~190	N190SPK	N19SPK	3.5~19	10	11	12	13	14					203	27	7	19.5	7.5	15	0.15				
					12	13	14						205	30										
					17	19								213	35									
380SPK	80~380	N380SPK	N38SPK	8~38	10	11	12	13	14					248	35	8	26.6	8.2	20	0.29				
					17	19							252	39										
					21	22	23	24					256	45										
					26	27	29	30	32					264	52	9								
					14	17	19	21						319	45	10					0.45			
670SPK	130~670	N670SPK	N67SPK	13~67	22	24	26							325	50	11	25.8	9.7	20	0.46				
					27	30	32						330	56								0.47		
					36	41							342	65								0.49		
					17	19	22						390	52								0.75		
1200SPK	240~1,200	N1200SPK	N120SPK	24~120	24	26	27							397	57	12	32.8	11.3	25	0.77				
					29	30	32						403	62								0.79		
					36	41							404	64	14							0.81		
					19	22								435	53	12				0.94				
1600SPK	300~1,600	N1600SPK	N160SPK	30~160	24	26							442	56					0.97					
					27	30	32	36					449	64	14					0.99				
					41								457	73					1.1					
					19	22								585	72	15	35.6	12.5	27.2	1.1				
2200SPK	450~2,200	N2200SPK	N220SPK	45~220	24	27																		1.2
					30	32	36																	1.4
					41									597	82				1.5					
					22	24								650	67	16	38.0	16	30	1.3				
3100SPK	650~3,100	N3100SPK	N310SPK	65~310	27	30	32						654	72								1.32		
					36	41							662	82								1.4		
					24	27								833	74	18	43.3	17.8	34	1.45				
4200SPK	900~4,200	N4200SPK	N420SPK	90~420	30	32							838	78								1.46		
					36								843	82								1.47		
					41									847	88				1.5					
					46									860	94				1.52					

* is the new model that is applied from 1st January, 2016.

RSPK PRE-SET, RING TORQUE WRENCHES

Can be used for accurate torque application even on joints inaccessible with other wrenches.

FEATURES

- The ring head of RSPK wrenches is offset at a 45° angle making certain joints particularly accessible.
- A single function wrench, used for a single setting combination of fastener size and torque setting.
- Most suited for tightening multiple same-size fasteners at the same torque on a production line.
- Setting confirmation unnecessary.
- Accuracy : ±3% of pre-set value

EXAMPLE OF ORDER

Model Size(W) Pre-set Value
 | | |
 N190RSPK 10 × 14N·m



Model	★1 Ring head sizes (W)			★2 Dimensions Head			Model	★3 Ring head sizes (W)			Dimensions Head		
	mm	S	T	mm	S	T		mm	S	T	mm	S	T
30RSPK N30RSPK	5.5	10	4	80RSPK N80RSPK	5.5	10	4	190RSPK N190RSPK	10	16	7		
	6		5		6		10		18				
	7	6	7		12	19	8						
	8	13	6		8	13	6		13	20	8.5		
	9	14	7		9	14	7		14	22	9		
	10	16	7	10	16	7	17	26	10				
				11	18	7	19	29	10.5				
				12	19	8	22	33	12				

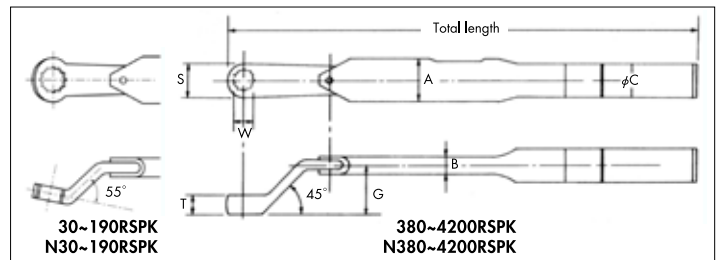

Model (kgf·cm)	Range (kgf·cm)	Old Model (N·m)	New Model (N·m)	Range (N·m)	Ring head sizes (W)				Total length (mm)	Dimensions (mm)						Weight (kg)	
					mm					Head		Body					
					S	T	G	A		B	C						
30RSPK	5~35	N30RSPK	N3.5RSPK	0.5~3.5	5.5	6			175	★ 1		19.5	7.5	15	0.12		
					7	8	9	10									
80RSPK	20~90	N80RSPK	N9RSPK	2~9	5.5	6	7		197	★ 2		19.5	7.5	15	0.13		
					8	9	10										
					11	12											
190RSPK	40~210	N190RSPK	N21RSPK	4~21	10				222	★ 3		19.5	7.5	15	0.21		
					11	12	13	14								225	
					17	19	22									228	
					11	12	13	14								268	22
					17	19	22									273	32
380RSPK	90~420	N380RSPK	N42RSPK	9~42	14	17			343	26	10	25	26.6	8.2	20		
					17	19	22									353	40
					27	30	32									413	32
670RSPK	140~730	N670RSPK	N73RSPK	14~73	19				413	32	12	27	25.8	9.7	20		
					19											413	32
					22	24										415	37
					27	30	32									428	44
					36											437	50
1200RSPK	250~1,270	N1200RSPK	N127RSPK	25~127	19				470	37	13	29	32.8	11.3	25		
					22	24										415	37
					27	30	32									428	44
					36											437	50
					19											413	32
1600RSPK	320~1,700	N1600RSPK	N170RSPK	32~170	19	22	24		470	37	15	31	32.8	11.3	25		
					27	30	32									474	44
					19											605	37
					22	24	27									608	41
					30	32										610	46
2200RSPK	480~2,300	N2200RSPK	N230RSPK	48~230	36				612	50	16.5	33	35.6	12.5	27.2		
					41											612	50
					41											612	50
					41											612	50
					41											612	50
3100RSPK	680~3,200	N3100RSPK	N320RSPK	68~320	22				682	40	18	35	38	16	30		
					24	27	30									685	46
					32	36										688	52
					41											688	52
					41											688	52
4200RSPK	950~4,300	N4200RSPK	N430RSPK	95~430	27	30	32		880	52	18	37	43.3	17.8	34		
					36											885	55
					41											890	60
					46											895	65
					46											895	65

* is the new model that is applied from 1st January, 2016.

QLK **ADJUSTABLE, RATCHET TORQUE WRENCHES**

Freely set torque values within the capacity range. Replaceable socket, ratchet wrenches.

FEATURES

- The ratchet improves efficiency. These wrenches are well suited for repetitive work.
- By replacing the sockets, various sizes of fasteners can be tightened within the tool's capacity range.
- By reversing the ratchet, the wrench can be used to loosen fasteners counter-clockwise.
- Tightening to a torque setting can only be done clockwise.
- Accuracy : ±3% of indicated value over the full range.



ADJUSTING THE TORQUE SETTING

◆ 30QLK~5600QLK

- (1) Loosen the lock screw. (See Fig.1)
- (2) Turn the sub-scale and adjust to a torque value (the main scale plus the sub-scale)(See Fig.2)
- (3) Tighten the lock screw. (If the lock screw hits the pin before completely tightening, then change the position of the pin)

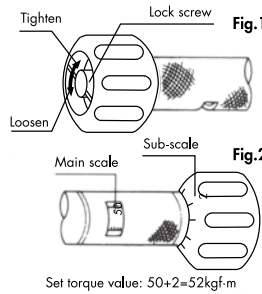

◆ 7000QLK~14000QLK

- (1) When applicable, mount the extension bar snugly all the way onto the body of the wrench.
- (2) With the extension bar mounted (See Fig.3), insert the hexagonal side of the adjusting box wrench.
- Without the extension bar (See Fig.4), insert the hexagonal side of the adjusting box wrench into the body.
- (3) Turn the adjusting box wrench to set the torque value. (the main scale plus the sub-scale)

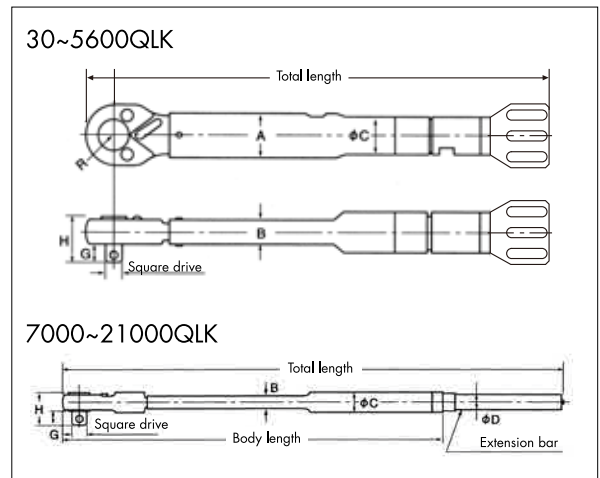
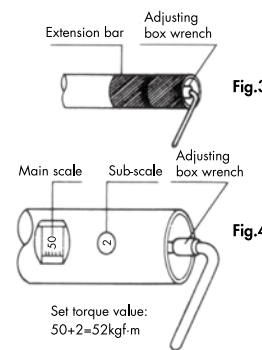

★ Torque adjusting box wrench

Increase torque clockwise / Reduce torque counter-clockwise

Size(mm)	
(N)7000QLK~10000QLK	8
(N)14000QLK~21000QLK	10

Model (kgf·cm/kgf·m)	Range (kgf·cm/kgf·m)	Increment (kgf·cm/kgf·m)	Old Model (cN·m/N·m)	New Model (cN·m/N·m)	Range (cN·m/N·m)	Increment (cN·m/N·m)	Model (lbf·in)	Range (lbf·in)	Increment (lbf·in)	Square drive (mm)	Total length (mm)	Dimensions (mm)							Weight (kg)	Standard Accessory	
												Head			Body						
											H	G	R	A	B	C	D	Body length			
30QLK	10~30	0.5	N30QLK	CN300QLK	100~300	5				6.35 (1/4")	187	18.8	7.5	12	18.2	9.6	15			0.19	
60QLK	20~60	1	N60QLK	N6QLK	2~6	0.1															
120QLK	40~120	2	N120QLK	N12QLK	4~12	0.2	PI 120QLK	40~120	2												
250QLK	50~250	2	N250QLK	N25QLK	5~25	0.2	PI 230QLK	70~230	2	9.53 (3/8")	232	25	11	15.5	16	25	11.4	20		0.28	
500QLK	100~500	5	N500QLK	N50QLK	10~50	0.5	PI 450QLK	100~450	5		257									0.47	
900QLK	200~900	10	N900QLK	N90QLK	20~90	1														0.81	
1000QLK	200~1000	10	N1000QLK	N100QLK	20~100	1	PI 1000QLK	200~1000	10		359	31	14	19.7	27.5	12.4	21.7		0.86		
1400QLK	400~1400	10	N1400QLK	N140QLK	40~140	1				12.7 (1/2")	399										
1800QLK	400~1800	20	N1800QLK	N180QLK	40~180	2					491	33	15.4	23	34					1.5	
2000QLK	400~2000	20	N2000QLK	N200QLK	40~200	2	PI 2000QLK	400~2000	20						15.4	27.2				1.95	
2800QLK	400~2800	20	N2800QLK	N280QLK	40~280	2					691	42		23.5	35					2.1	
3600QLK	800~3600	20	N3600QLK	N360QLK	80~360	2														2.1	
4200QLK	6~42	0.2	N4200QLK	N420QLK	60~420	2				19.05 (3/4")	965	42.7	20	27.5	38	16	30			3.3	
5600QLK	8~56	0.3	N5600QLK	N560QLK	80~560	3					1,195	49.5		34	43.5	18	34			5	
7000QLK	10~70	0.5	N7000QLK	N700QLK	100~700	5					1,314				46	19.2	35.4	27.2	990	6.2	
8500QLK	10~85	0.5	N8500QLK	N850QLK	100~850	5					1,388									8.5	
10000QLK	10~100	0.5	N10000QLK	N1000QLK-8	100~1000	5				25.4 (1")	1,538	58	27	38	54	23	42.7	31.8	1,105	8.8	
15000QLK	20~150	1	N15000QLK	N1500QLK	200~1500	10					1,844									14	
21000QLK	70~210	1	N21000QLK	N2100QLK	700~2100	10					2,064	61		43.5	66	26	51	40	1,144	14	Torque adjusting box wrench

* [Pink box] is the new model that is applied from 1st January, 2016.

GLK **ADJUSTABLE, RATCHET TORQUE WRENCHES WITH PLASTIC GRIP**

Freely set torque values within the capacity range. Replaceable socket, ratchet wrenches.

FEATURES

- The ratchet improves efficiency. These wrenches are well suited for repetitive work.
- By replacing the sockets, various sizes of fasteners can be tightened within the tool's capacity range.
- By reversing the ratchet, the wrench can be used to loosen fasteners counter-clockwise.
- Tightening to a torque setting can only be done clockwise.
- Accuracy : $\pm 3\%$ of indicated value over the full range.



60~1400GLK

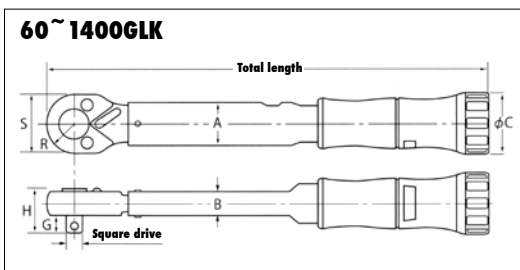

Model (kgf·cm)	Range	Increment	Model (N·m)	Range	Increment	Square drive	Total length	Dimensions (mm)							Weight
								Head			Body				
	kgf·cm	kgf·cm		N·m	N·m	mm	mm	H	G	S	R	A	B	φ C	kg
60GLK	20~60	1	N6GLK	2~6	0.1	6.35 (1/4")	187	18.8	7.5	24	12	18.2	9.6	29	0.2
120GLK	40~120	2	N12GLK	4~12	0.2										0.28
250GLK	50~250	2	N25GLK	5~25	0.2	9.53 (3/8")	233	25	11	31	15.5				
500GLK	100~500	5	N50GLK	10~50	0.5		255			32	16	25	11.4	35	0.47
1000GLK	200~1000	10	N100GLK	20~100	1		355								0.8
1400GLK	400~1400	10	N140GLK	40~140	1	12.7 (1/2")	395	31	14	39.4	19.7	27.5	12.4	38	0.87
2000GLK	400~2000	20	N200GLK	40~200	2		480	33	15.4	46	23	34	15.4	40	1.48

BLK **ADJUSTABLE BY HEX WRENCH, RATCHET TORQUE WRENCHES WITH PLASTIC GRIP**

Freely set torque values within the capacity range. Replaceable socket, ratchet wrenches.

FEATURES

- Adjusted setting torque value by hex wrench.
- The ratchet improves efficiency. These wrenches are well suited for repetitive work.
- By replacing the sockets, various sizes of fasteners can be tightened within the tool's capacity range.
- By reversing the ratchet, the wrench can be used to loosen fasteners counter-clockwise.
- Tightening to a torque setting can only be done clockwise.
- Accuracy : $\pm 3\%$ of indicated value over the full range.



250~1000BLK

*Hex wrench is not included

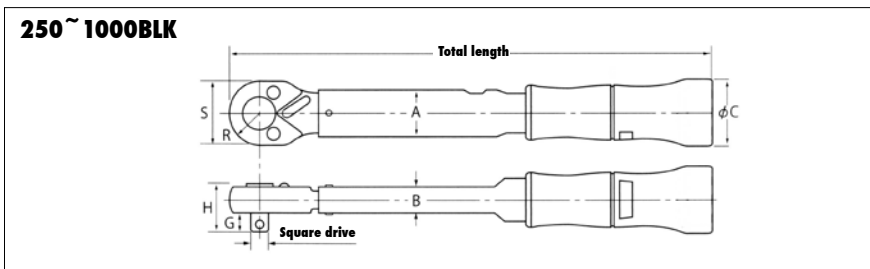

Model (kgf·cm)	Range	Increment	Model (N·m)	Range	Increment	Square drive	Total length	Dimensions (mm)						Weight
								Head			Body			
	kgf·cm	kgf·cm		N·m	N·m	mm	mm	H	G	R	A	B	C	kg
250BLK	50~250	2	N25BLK	5~25	0.2	9.53 (3/8")	245	25	11	15.5	18.2	9.6	30	0.27
500BLK	100~500	5	N50BLK	10~50	0.5					16	25	11.4	33	0.43
1000BLK	200~1000	10	N100BLK	20~100	1	12.7 (1/2")	392	31	14	19.7	27.5	12.4	36	0.72

QSPK PRE-SET, RATCHET TORQUE WRENCHES, METAL HANDLE

Pre-set torque value. Improved work efficiency with ratchet square drive.

FEATURES

- The ratchet drive enables quickly tightening fasteners to the preset torque. Suitable for repetitive jobs.
- The wrench's inner mechanism automatically resets itself for the the next job after disengaging from a tightened joint.
- Accuracy : ±3% of set value.

EXAMPLE OF ORDER

Model Pre-set Value
| |
N900QSPK × 72N·m

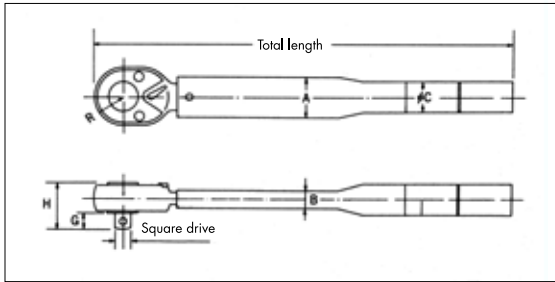

Model (kgf·cm)	Range kgf·cm	Old Model (N·m)	New Model (N·m)	Range N·m	Model (lbf·in/lbf·ft)	Range lbf·in/lbf·ft	Square drive mm	Total length mm	Dimensions (mm)						Weight kg
									Head			Body			
								H	G	R	A	B	C		
60QSPK	20~60	N60QSPK	N6QSPK	2~6	PI 60QSPK	20~60 lbf·in	6.35 (1/4")	174	19.5	7.5	12.5	18.2	9.6	15	0.17
120QSPK	40~120	N120QSPK	N12QSPK	4~12	PI 120QSPK	40~120 "									0.25
250QSPK	50~250	N250QSPK	N25QSPK	5~25	PI 230QSPK	70~230 "	9.53 (3/8")	220	25	12	16	25	11.4	20	0.38
500QSPK	100~500	N500QSPK	N50QSPK	10~50	PI 450QSPK	100~450 "		240							0.64
1000QSPK	200~1000	N1000QSPK	N100QSPK	20~100	PI 900QSPK	200~900 "		340							0.7
1400QSPK	400~1400	N1400QSPK	N140QSPK	40~140	PI 1400QSPK	400~1400 "	12.7 (1/2")	380	31	14	19.7	27.5	12.4	21.7	1.35
2000QSPK	400~2000	N2000QSPK	N200QSPK	40~200	PI 1800QSPK	400~1800 "		463.5	33			23	34	15.4	27.2
2800QSPK	600~2800	N2800QSPK	N280QSPK	60~280	PI 2800QSPK	600~2800 "		664	42						2.0
4200QSPK	600~4200	N4200QSPK	N420QSPK	60~420	PF 300QSPK	50~300 lbf·ft	19.05 (3/4")	980	49.5	20	34	43.5	18	34	4.3

QSPKH, QSPK-A PRE-SET, RATCHET TORQUE WRENCHES WITH PLASTIC GRIP

Pre-set torque value. Improved work efficiency with ratchet square drive.

FEATURES

- The ratchet drive enables quickly tightening fasteners to the preset torque. Suitable for repetitive jobs.
- The wrench's inner mechanism automatically resets itself for the the next job after disengaging from a tightened joint.
- Accuracy : ±3% of set value.



■ H-type : The end cap is removed with a slotted screwdriver to adjust torque.

Model (kgf·cm)	Range kgf·cm	Old Model (N·m)	New Model (N·m)	Range N·m	Square drive mm	Total length mm	Dimensions (mm)						Weight kg
							Head			Body			
							H	G	R	A	B	C	
60QSPKH	20~60	N60QSPKH	N6QSPKH	2~6	6.35 (1/4")	174	19.5	7.5	12.5	18.2	9.6	26.5	0.19
120QSPKH	40~120	N120QSPKH	N12QSPKH	4~12									0.27
250QSPKH	50~250	N250QSPKH	N25QSPKH	5~25	9.53 (3/8")	220	25	12	16	25	11.4	32.7	0.41
500QSPKH	100~500	N500QSPKH	N50QSPKH	10~50		240							0.69
1000QSPKH	200~1000	N1000QSPKH	N100QSPKH	20~100		340							0.75
1400QSPKH	400~1400	N1400QSPKH	N140QSPKH	40~140	12.7 (1/2")	380	31	14	19.7	27.5	12.4	37	

■ A-type : Adjusted setting torque value by hex wrench.

Model (kgf·cm)	Range kgf·cm	Old Model (N·m)	New Model (N·m)	Range N·m	Square drive mm	Total length mm	Dimensions (mm)						Weight kg
							Head			Body			
							H	G	R	A	B	C	
60QSPK-A	20~60	N60QSPK-A	N6QSPK-A	2~6	6.35 (1/4")	174	19.5	7.5	12.5	18.2	9.6	26.5	0.19
120QSPK-A	40~120	N120QSPK-A	N12QSPK-A	4~12									0.27
250QSPK-A	50~250	N250QSPK-A	N25QSPK-A	5~25	9.53 (3/8")	220	25	12	16	25	11.4	32.7	0.41
500QSPK-A	100~500	N500QSPK-A	N50QSPK-A	10~50		240							0.69
1000QSPK-A	200~1000	N1000QSPK-A	N100QSPK-A	20~100		340							0.75
1400QSPK-A	400~1400	N1400QSPK-A	N140QSPK-A	40~140	12.7 (1/2")	380	31	14	19.7	27.5	12.4	37	

Note : Use a KANON torque wrench analyzer when adjusting torque. Without the analyzer, torque cannot be adjusted.

* is the new model that is applied from 1st January, 2016.



QSPKH

* Adjusting tool is option



QSPK-A

* Hex wrench is option

SPCK PRE-SET, REPLACEABLE HEAD TORQUE WRENCHES

Work at a set torque value can proceed smoothly while using various replaceable heads.

FEATURES

- Replaceable ratchet, open end wrench, ring, and hex drive heads are available.
- Pre-set torque wrench well suited for repetitive jobs at the specified torque value.
- Accuracy : $\pm 3\%$ of pre-set value

USING AN SPCK

Mount the head on the drive.

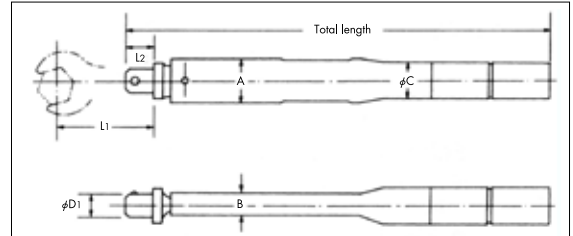
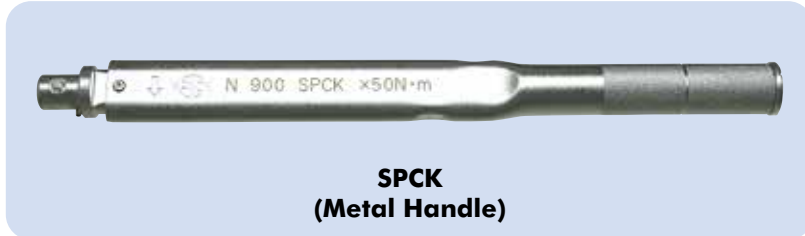

Model (kgf·cm)	Range kgf·cm	Old Model (N·m)	New Model (N·m)	Range N·m	Total length mm	Dimensions (mm)						Weight kg	Replaceable heads
						Head			Body				
						phi D1	L1	L2	A	B	phi C		
60SPCK	20~60	N60SPCK	N6SPCK	2~6	161	10	45	13	18.2	9.6	15	0.15	12QCK, 25 (QCK, SCK, RCK, HCK)
120SPCK	40~120	N120SPCK	N12SPCK	4~12								0.19	25 (QCK, SCK, RCK, HCK)
250SPCK	50~250	N250SPCK	N25SPCK	5~25	196	12	55	16	25	11.4	20	0.27	50 (QCK, SCK, RCK, HCK)
500SPCK	100~500	N500SPCK	N50SPCK	10~50	220							0.57	100 (QCK, SCK, RCK, HCK, NCK)
1000SPCK	200~1,000	N1000SPCK	N100SPCK	20~100	312	15	65	18	27.5	12.4	21.7	0.92	200 (QCK, SCK, RCK, HCK, NCK)
2000SPCK	400~2,000	N2000SPCK	N200SPCK	40~200	428							1.7	280 (QCK, SCK, RCK, HCK)
2800SPCK	600~2,800	N2800SPCK	N280SPCK	60~280	590	22	100	27	38	16	27.2	2.6	440 (QCK, SCK, RCK)
4400SPCK	600~4,400	N4400SPCK	N440SPCK	60~440	893							39	30

SPCKH PRE-SET, REPLACEABLE HEAD TORQUE WRENCHES WITH PLASTIC GRIP

Work at a set torque value can proceed smoothly while using various replaceable heads.



Optional Replaceable Heads (Refer to the page 10)

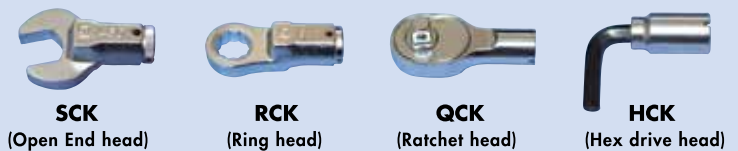

Model (kgf·cm)	Range kgf·cm	Old Model (N·m)	New Model (N·m)	Range N·m	Total length mm	Dimensions (mm)						Weight kg	Replaceable heads
						Head			Body				
						phi D1	L1	L2	A	B	phi C		
60SPCKH	20~60	N60SPCKH	N6SPCKH	2~6	161	10	45	13	18.2	9.6	26.5	0.17	12QCK, 25 (QCK, SCK, RCK, HCK)
120SPCKH	40~120	N120SPCKH	N12SPCKH	4~12								0.21	25 (QCK, SCK, RCK, HCK)
250SPCKH	50~250	N250SPCKH	N25SPCKH	5~25	196	12	55	16	25	11.4	32.7	0.3	50 (QCK, SCK, RCK, HCK)
500SPCKH	100~500	N500SPCKH	N50SPCKH	10~50	220							0.62	100 (QCK, SCK, RCK, HCK, NCK)
1000SPCKH	200~1,000	N1000SPCKH	N100SPCKH	20~100	312	15	65	18	27.5	12.4	37	0.62	100 (QCK, SCK, RCK, HCK, NCK)

RE-SETTING THE PRE-SET TORQUE

(SPK · RSPK · QSPK · SPCK · TYPES)

- (1) Remove the screw cap with a slot drive screw driver.
- (2) Loosen the setting screw with a hex wrench.
- (3) Using the special adjusting tool or equivalent, rotate the slotted plate clockwise to increase torque or counterclockwise to reduce torque. Check the setting with a torque analyzer.
- (4) Tighten the setting screw with a hex wrench.
- (5) Screw on the screws cap and tighten it.

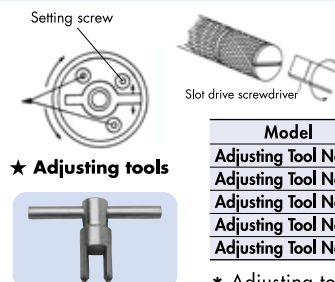

Model	Applicable Torque wrench Tools
Adjusting Tool No.1	(N)30,80,190SPK(H), (N)30,80,190RSPK(H), (N)60,120,230,250QSPK(H)
Adjusting Tool No.2	(N)380,670SPK(H), (N)380,670RSPK(H), (N)450,500,900,1000,1400QSPK(H)
Adjusting Tool No.3	(N)1200,1600,2200SPK, (N)1200,1600,2200RSPK, (N)1800,2000QSPK, (N)2800 QSPK
Adjusting Tool No.4	(N)3100SPK, (N)3100RSPK, (N)4200QSPK
Adjusting Tool No.5	(N)4200SPK, (N)4200RSPK

* Adjusting tool is option.

* is the new model that is applied from 1st January, 2016.

LCK **ADJUSTABLE, REPLACEABLE HEAD TORQUE WRENCHES**

Freely replace heads according to work applications. The combination of replaceable heads and torque adjustability make this series extremely versatile.

FEATURES

- Ring, ratchet, open end wrench and hex drive heads are available.
- The torque can be set to any value within the capacity range.
- Models are available ranging from 20 kgf·cm to 14,000 kgf·cm.
- Accuracy : ±3% of indicated value over the full range



LCK

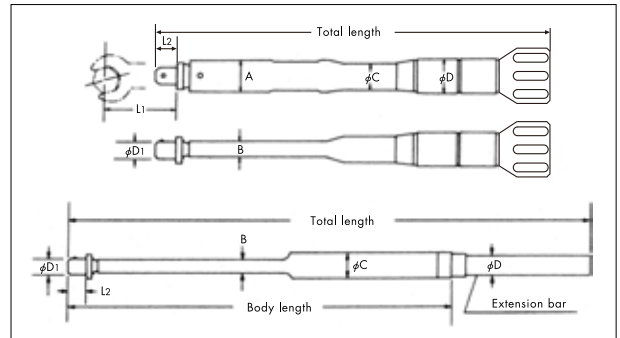

Model (kgf·cm/kgf·m)	Range kgf·cm/kgf·m	Increment kgf·cm/kgf·m	Old Model (N·m)	New Model (N·m)	Range N·m	Increment N·m	Total length mm	Dimensions (mm)							Weight kg	Replaceable heads								
								Head			Body													
								phi D1	L1	L2	A	B	C	D	Body length									
60LCK	20 ~ 60 kgf·cm	1 kgf·cm	N60LCK	N6LCK	2 ~ 6	0.1	174	10	45	13	18.2	9.6	15			0.18	12QCK, 25 (QCK, SCK, RCK, HCK)							
120LCK	40 ~ 120 //	2 //	N120LCK	N12LCK	4 ~ 12	0.2										0.21	25 (QCK, SCK, RCK, HCK)							
250LCK	50 ~ 250 //	2 //	N230LCK	N25LCK	5 ~ 25	0.2										208	0.38	50 (QCK, SCK, RCK, HCK)						
500LCK	100 ~ 500 //	5 //	N450LCK	N50LCK	10 ~ 50	0.5	238	12	55	16	25	11.4	20			0.6	100 (QCK, SCK, RCK, HCK, NCK)							
1000LCK	200 ~ 1000 //	10 //	N900LCK	N100LCK	20 ~ 100	1	331	15	65	18	27.5	12.4	21.7			1.35	200 (QCK, SCK, RCK, HCK, NCK)							
2000LCK	400 ~ 2,000 //	20 //	N1800LCK	N200LCK	40 ~ 200	2	455	18	80	22	34	15.4	27.2			1.81	280 (QCK, SCK, RCK, HCK, NCK)							
2800LCK	4 ~ 28 kgf·m	0.2 kgf·m	N2800LCK	N280LCK	40 ~ 280	2	653	22	100	27	39	16	30			2.8	440 (QCK, SCK, RCK)							
4400LCK	6 ~ 44 //	0.2 //	N4400LCK	N440LCK	60 ~ 440	2	908	30	125	45	43.5	18	34	27.2	876	4.1	700 (QCK, SCK, RCK)							
5600LCK	8 ~ 56 //	0.3 //	N5600LCK	N560LCK	80 ~ 560	3	1086									46		19.2	35.4					5.1
7000LCK	10 ~ 70 //	0.5 //	N7000LCK	N700LCK	100 ~ 700	5	1206																	7.2
8500LCK	10 ~ 85 //	0.5 //	N8500LCK	N850LCK	100 ~ 850	5	1267	34	130	47	54	23	42.7	31.8	984	7.5	1000 (QCK, SCK, RCK)							
10000LCK	10 ~ 100 //	0.5 //	N10000LCK	N1000LCK	100 ~ 1,000	5	1417	38	160	60	66	26	51	40	1003	13.5	2100QCK, 1500 (SCK, RCK)							
15000LCK	20 ~ 150 //	1 //	N14000LCK	N1500LCK	200 ~ 1,500	10	1700																	

GCK **ADJUSTABLE, REPLACEABLE HEAD TORQUE WRENCHES WITH PLASTIC GRIP**

Freely replace heads according to work applications. The combination of replaceable heads and torque adjustability make this series extremely versatile.

FEATURES

- Ring, ratchet, open end wrench and hex drive heads are available.
- The torque can be set to any value within the capacity range.
- Models are available ranging from 20 kgf·cm to 1,400 kgf·cm.
- Accuracy : ±3% of indicated value over the full range



GCK

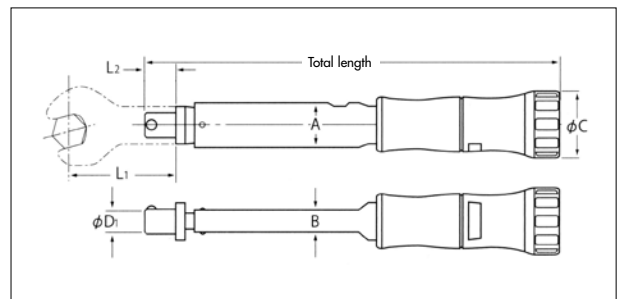

Model (kgf·cm)	Range kgf·cm	Increment kgf·cm	Model (N·m)	Range N·m	Increment N·m	Total length mm	Dimensions (mm)						Weight kg	Replaceable heads	
							Head			Body					
							phi D1	L1	L2	A	B	C			
60GCK	20 ~ 60	1	N6GCK	2 ~ 6	0.1	174	10	45	13	18.2	9.6	29		0.18	12QCK, 25 (QCK, SCK, RCK, HCK)
120GCK	40 ~ 120	2	N12GCK	4 ~ 12	0.2									0.21	25 (QCK, SCK, RCK, HCK)
250GCK	50 ~ 250	2	N25GCK	5 ~ 25	0.2									209	0.37
500GCK	100 ~ 500	5	N50GCK	10 ~ 50	0.5	235	12	55	16	25	11.4	35		0.6	100 (QCK, SCK, RCK, HCK, NCK)
1000GCK	200 ~ 1,000	10	N100GCK	20 ~ 100	1	327	15	65	18	27.5	12.4	38		0.68	200 (QCK, SCK, RCK, HCK, NCK)
1400GCK	400 ~ 1,400	10	N140GCK	40 ~ 140	1	365	18	80	22	34	15.4	40		1.3	200 (QCK, SCK, RCK, HCK, NCK)
2000GCK	400 ~ 2,000	20	N200GCK	40 ~ 200	2	480									

* is the new model that is applied from 1st January, 2016.

HEADS

OPTIONAL REPLACEABLE HEADS

SCK (Open End head)

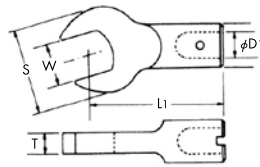

QCK (Ratchet head)

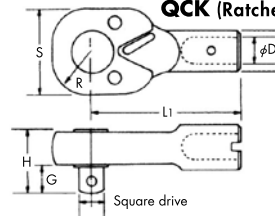

SCK open end heads

Unit : mm

Old Model	New Model	Size (W)					S	T	L1	φ D1	Applicable torque wrench
230SCK	25SCK	7	8	9	10		29	7	45	10	60-250LCK, N6-N25LCK, 60-250SPCK, N6-N25SPCK, 250GCK, N25GCK, DTC-20REV, DTC-50REV, DTC-100REV, DTC-CN200REV, DTC-CN500REV, DTC-N10REV, DTC-PI-40REV, DTC-PI80REV
		11									
		12	13	14	15	16	32				
		17	19	21	22		39				
		24					45				
450SCK	50SCK	8	9	10	11		32	8	55	12	
		12	13	14	15	16	36				
		17	19	21	22		44				
		24	27				50				
900SCK	100SCK	12	13	14	15		40	10	65	15	
		16	17	19	21	22	48				
		24	27	30			57				
1800SCK	200SCK	17	19	21	22		56	14	80	18	
		24	27	30			64				
		32	36	41			75				
2800SCK	280SCK	19					59	16	100	22	
		21	22				61				
		24					63				
		27					67				
		30					69				
		32					71				
		36					75				
		41					80				
		46					85				
		19	22	24			70	20			100
27	30	32			78						
36	41				84						
46	50				94						
55	60				100						
27					83	25	125	30			
30					86						
32					88						
36					91						
41					95						
46					98						
50					102						
55					105						
60					110						
36					95	30			130	34	
41					100						
46					106						
50					110						
55					115						
60					120						
41					110	32	160	38			
46					115						
50					120						
55					122						
60					127						
65					130						

QCK ratchet heads

Unit : mm

Old Model	New Model	Sq. drive	S	H	G	R	L1	φ D1	Applicable torque wrench						
120QCK	12QCK	6.35 (1/4")	24	19	7.5	12	45	10	60-250LCK, N6-N25LCK, 60-250SPCK, N6-N25SPCK, 250GCK, N25GCK, DTC-20REV, DTC-50REV, DTC-100REV, DTC-CN200REV, DTC-CN500REV, DTC-N10REV, DTC-PI-40REV, DTC-PI80REV						
230QCK	25QCK	9.53 (3/8")	31	25	11	15.5									
450QCK	50QCK		32			16	55	12							
900QCK	100QCK	12.7 (1/2")	39	31	14	19.7	65	15							
1800QCK	200QCK		46	33		23	80	18							
2800QCK-A	280QCK-A	19.05 (3/4")	54	42.5	20	27	100	22		2800LCK, N280LCK, 2800SPCK, N280SPCK, DTC-3000REV, DTC-N300REV, DTC-PF200REV					
4400QCK	440QCK									4400LCK, N440LCK, 4400SPCK, N440SPCK					
7000QCK	700QCK									68	50	34	125	30	5600, 7000LCK, N560, N700LCK, DTC-5000REV, DTC-N500REV, DTC-PF400REV
10000QCK	1000QCK									76	58	27	38	130	34
21000QCK	2100QCK	25.4 (1")	87	61	28.5	43.5	160	38		15000LCK, N1500LCK					

* is the new model that is applied from 1st January, 2016.

HEADS

OPTIONAL REPLACEABLE HEADS

RCK (Ring head)

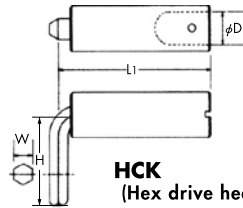
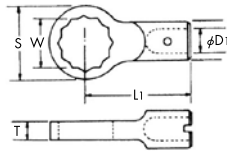

HCK (Hex drive head)

RCK ring heads

Unit : mm

Old Model	New Model	Size (W)				S	T	L ₁	φD ₁	Applicable torque wrench
230RCK	25RCK	7	8	9	10	18	8	45	10	60-250LCK, N6-N25LCK, 60-250SPCK, N6-N25SPCK, 250GCK, N25GCK, DTC-20REV, DTC-50REV, DTC-100REV, DTC-CN200REV, DTC-CN500REV, DTC-N10REV, DTC-PI-40REV, DTC-PI80REV
		11				21				
		12	13	14		31				
		17	19	22		32				
		24								
450RCK	50RCK	8	10			19	10	55	12	500LCK, N50LCK, 500SPCK, N50SPCK, 500GCK, N50GCK, DTC-500REV, DTC-N50REV, DTC-PI400REV, DLT-N50UC
		11	12	13	14	32				
		17	19	22						
900RCK	100RCK	12	13	14		25	13	65	15	1000LCK, N100LCK, 1000SPCK, N100SPCK, 1000, 1400GCK, N100, N140GCK, DTC-1000REV, DTC-N100REV, DTC-PI800REV, DLT-N100-UC
		17	19	21	22	34				
		24	27	30		42				
1800RCK	200RCK	17	19	22		35	15	80	18	2000LCK, N200LCK, 2000SPCK, N200SPCK, 2000GCK, N200GCK, DTC-2000REV, DTC-N200REV, DTC-PF100REV, DLT-N200-UC
		24	27	30		45				
		32	36	41		58				
2800RCK	280RCK	19	22	24		40	17	100	22	2800LCK, N280LCK, 2800SPCK, N280SPCK, DTC-3000REV, DTC-N300REV, DTC-PF200REV
		27	30	32		47				
		36	41			63				
4400RCK	440RCK	19	22	24		44	20	100	22	4400LCK, N440LCK, 4400SPCK, N440SPCK
		27	30	32		50				
		36	41			58				
		46	50			66				
		55	60			80				
7000RCK	700RCK	27	30	32		57	20	125	30	5600, 7000LCK, N560, N700LCK, DTC-5000REV, DTC-N500REV, DTC-PF400REV
		36				62				
		41				70				
		46	50			80				
		55				80				
10000RCK	1000RCK	36				65	25	130	34	8500, 10000LCK, N850, N1000LCK, DTC-10000REV, DTC-N1000REV
		41				28				
		46				72				
		50				30				
		55				80				
14000RCK	1500RCK	41				75	27	160	38	15000LCK, N1500LCK
		46				30				
		50				80				
		55				32				
		60				90				

HCK hex drive heads

Unit : mm

Old Model	New Model	Size (W)	L ₁	φD ₁	Size (H)	Applicable torque wrench
230HCK	25HCK	2.5	45	10	19	60-250LCK, N6-N25LCK, 60-250SPCK, N6-N25SPCK, 250GCK, N25GCK, DTC-20REV, DTC-50REV, DTC-100REV, DTC-CN200REV, DTC-CN500REV, DTC-N10REV, DTC-PI-40REV, DTC-PI80REV
		3			22	
		4			25	
		5			30	
		6			35	
		8			40	
		8			40	
450HCK	50HCK	4	55	12	27	500LCK, N50LCK, 500SPCK, N50SPCK, 500GCK, N50GCK, DTC-500REV, DTC-N50REV, DTC-PI400REV, DLT-N50UC
		5			30	
		6			35	
		8			40	
		10			45	
		10			45	
900HCK	100HCK	6	65	15	35	1000LCK, N100LCK, 1000SPCK, N100SPCK, 1000, 1400GCK, N100, N140GCK, DTC-1000REV, DTC-N100REV, DTC-PI800REV, DLT-N100-UC
		8			40	
		10			45	
		12			51	
		14			63	
1800HCK	200HCK	8	80	18	40	2000LCK, N200LCK, 2000SPCK, N200SPCK, 2000GCK, N200GCK, DTC-2000REV, DTC-N200REV, DTC-PF100REV, DLT-N200-UC
		10			45	
		12			51	
		14			63	
		17			72	
2800HCK	280HCK	12	100	22	51	2800LCK, N280LCK, 2800SPCK, N280SPCK, DTC-3000REV, DTC-N300REV, DTC-PF200REV
		14			63	
		17			71	
		17			71	
		19			80	

* is the new model that is applied from 1st January, 2016.

HEADS

OPTIONAL REPLACEABLE HEADS

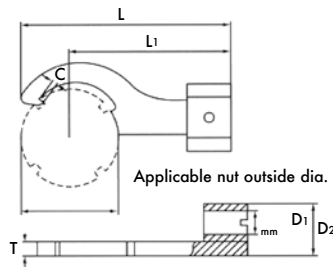

■ Applicable nut outside dia.

Unit : mm

Model	Range	T	C	L	L ₁	φD ₁	φD ₂	Applicable torque wrench
100NCK3032	30 ~ 32	5	2.3	81	65	15	28	1000LCK, N100LCK, 1000SPCK, N100SPCK, 1000, 1400GCK, N100, N140GCK, DTC-1000REV, DTC-N100REV, DTC-P1800REV, DLT-N100-UC
100NCK3438	34 ~ 38	6	2.5	85			29	
100NCK4042	40 ~ 42	6	2.5	88			29.5	
100NCK4548	45 ~ 48	6.5	2.5	91			29.5	
100NCK5055	50 ~ 55	6.5	2.5	94	80	18	33.5	2000LCK, N200LCK, 2000SPCK, N200SPCK, 2000GCK, N200GCK, DTC-2000REV, DTC-N200REV, DTC-PF100REV, DLT-N200-UC
200NCK5865	58 ~ 65	7.5	3	112			33.5	
200NCK6570	65 ~ 70	7.5	3	112			34	
200NCK7075	70 ~ 75	8	3.5	117			34.5	
200NCK8085	80 ~ 85	8.5	3.5	121			34.5	
200NCK92100	92 ~ 100	8.5	4	126				

ZLK

KANON insulated adjustable torque wrench

Special 2-layer insulation coating preventing shock hazard



FEATURES

- Torque value preset is available within the capacity according to your need.
- Special 2-layer insulation coating is a risk protection for users against shock hazard.
- Damage to coating is easy to recognize from the different color for the top and the bottom layer of special 2-layer insulation coating.
- Withstand voltage is 1000V AC at maximum.
- Best for maintenance and inspection for electric vehicles
- Exclusive design for cw tightening
- The accuracy is guaranteed within a tolerance of 3%.

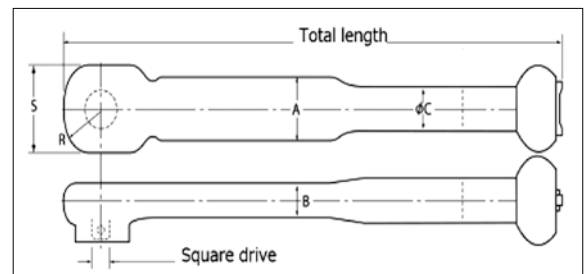

Model (N·m)	Range	Increment	Square Drive	Total length	Dimensions (mm)					Weight
					Head		Body			
					S	R	A	B	φC	
N50ZLK	10~50	0.5	9.53 (3/8")	287	38	19	31	17.4	26	0.52
N100ZLK	20~100	1	12.7 (1/2")	392	45	22.5	33.5	19.4	19.4	0.89

QLK-LR LARGE HUB NUT TORQUE WRENCHES

Ideal for tightening hub nuts on large trucks and buses

FEATURES

- Dual square drives for both clockwise and counterclockwise tightening.
- By replacing the sockets, various sizes of fasteners can be tightened within the tool's capacity range.
- By reversing the switch on the ratchet, the wrench can be used to loosen fasteners. Tightening to a torque setting, however, can only be done in the direction of the arrow.
- Accuracy : ±3% of indicated value over the full range

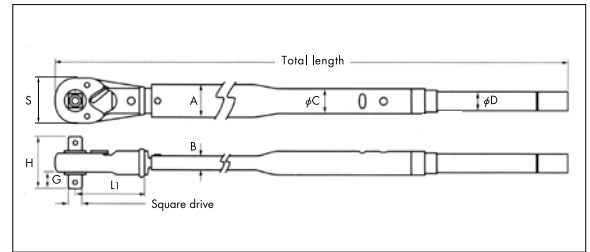

Model (kgf·m)	Range (kgf·m)	Increment	Old Model (N·m)	New Model (N·m)	Range (N·m)	Increment	Square drive (mm)	Total length (mm)	Dimensions (mm)								Weight (kg)	Standard Accessory	
									Head				Body						
									S	G	H	L1	A	B	φC	φD			
7000QLK-LR	10~70	0.5	N7000QLK-LR	N700QLK-LR	100~700	5	19.05 (3/4")	1,314	68	20	70	125	49	20	35.4	27.2	6.2	Torque adjusting box wrench	
8500QLK-LR	10~85		N8500QLK-LR	N850QLK-LR	100~850		25.4 (1")	1,388											8.5
10000QLK-LR	10~100		N10000QLK-LR	N1000QLK-LR	100~1000			1,538	76	27	85	168	54	23	42.7	31.8	8.8		



Old Model (Replaceable Head)	New Model (Replaceable Head)	Square drive (mm)	Applicable torque wrench
7000QCK-LR	700QCK-LR	19.05 (3/4")	(N)5600~7000LCK
10000QCK-LR	1000QCK-LR	25.4 (1")	(N)8500~10000LCK

HYK ADJUSTABLE WRENCH HEADS, ADJUSTABLE TORQUE WRENCHES

Built-in "no play" worm screw

FEATURES

- Since the head can be taken off and reversed, the wrench can be used in confined spaces (in as small as a 30 degree turn) previously inaccessible to even other adjustable wrenches. (Tightening to a torque setting can only be done in the direction of the arrow.)
- There is hardly any play in the worm screw adjuster in the wrench head, which will improve your working efficiency. Without excess play, the torque wrench will not damage the corners of fasteners like ordinary wrenches will.
- Accuracy : ±4% of indicated value over the full range



USING AN HYK

Setting the opening

- (1) Slide the jaws onto the fastener until it contacts the spring pin. (a)
- (2) Tighten the adjusting worm screw so the jaws grip the fastener. (b)
- (3) Loosen the adjusting worm screw just enough to allow removing the wrench from the fastener. (c)

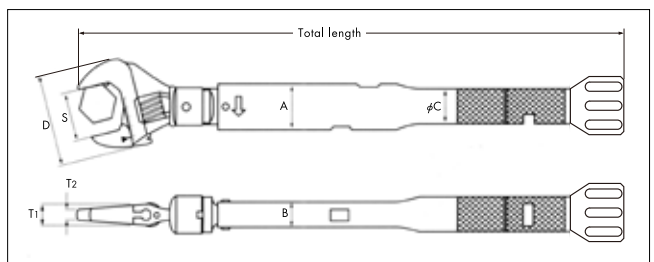
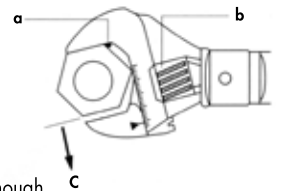

Model (kgf·m)	Range (kgf·cm)	Increment	Model (N·m)	Range (N·m)	Increment	Total length (mm)	Opening Size (mm)	Dimensions (mm)							Weight (kg)
								Head			Body				
							S	D	T1	T2	A	B	φC		
450HYK	100~450	5	N45HYK	10~45	0.5	288	10~26	49	10	5.5	25	11.4	20	0.48	
1000HYK	200~1000	10	N100HYK	20~100	1	393	10~30	59	12	6	27.5	12.4	21.7	0.76	
1800HYK	400~1800	20	N180HYK	40~180	2	531	17~38	67	12.5	6.5	34	15.4	27.2	1.47	

MCK

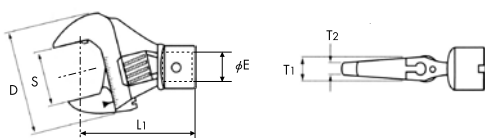

Model (Replaceable Head)	Opening Size (mm)	Dimensions (mm)					Applicable torque wrench
		D	φE	L1	T1	T2	
45MCK	10~25	49	10	5.5	25	11.4	N4500CK, N4500S00CK, DTC5000L, DTC700000L, DTC100000L, DTC150000L
100MCK	10~30	59	12	6	27.5	12.4	N10000CK, N10000S00CK, DTC100000L, DTC150000L, DTC200000L, DTC250000L, DTC300000L, DTC350000L, DTC400000L, DTC450000L, DTC500000L, DTC550000L, DTC600000L, DTC650000L, DTC700000L, DTC750000L, DTC800000L, DTC850000L, DTC900000L, DTC950000L, DTC1000000L
180MCK	17~38	67	12.5	6.5	34	15.4	N18000CK, N18000S0000CK, DTC200000L, DTC250000L, DTC300000L, DTC350000L, DTC400000L, DTC450000L, DTC500000L, DTC550000L, DTC600000L, DTC650000L, DTC700000L, DTC750000L, DTC800000L, DTC850000L, DTC900000L, DTC950000L, DTC1000000L

DLT-N KANON DIGITAL TORQUE WRENCH

Digital control for ease of use and handling. Precise control of torque at a low cost.



DLT-N100

Optional Replaceable Heads (Refer to the page 10)



SCK
(Open End head)



RCK
(Ring head)



HCK
(Hex drive head)

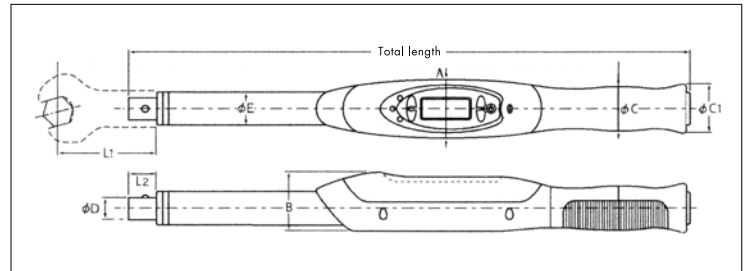

FEATURES

- The digital torque wrench DLT-N series measures and digitally displays tightening torque and return torque.
- Preset function: Set the tightening torque before operation, and the LED and a buzzer tell you when the preset torque is reached during operation.
- Data memory function: Connect the torque wrench after use to your PC, and the measurement data is stored in the PC for editing in the Excel format (Windows Excel only).
- Powered by 2 rechargeable nickel-metal hydride (Ni-MH) batteries, which are recharged via the USB port of the torque wrench while they are in the wrench.
- Auto power-off: Saves power to enable use of the unit for a longer time.
- Calendar function: Date and time of tightening operations are stored in the memory.
- Smart and slim design based on a new concept.
- The head is easily replaceable to suit different purposes of use.
- $\pm 2\% + 1$ digit guaranteed accuracy ($\pm 3\% + 1$ digit for DLT-N50-UC).

Names and Functions of Components



- ① Power key: Power ON/OFF; clears measured value in PA mode.
- ② Data key: Saves and calls data.
- ③ Mode key: Selects the measurement mode.
- ④ UP key: Sets tightening torque in the preset mode; searches a particular data in the data calling mode; sets calendar and clock.
- ⑤ DOWN key: Sets tightening torque in the preset mode; searches a particular data in the data calling mode; sets calendar and clock.
- ⑥ LED: Flashes to indicate that the preset torque is soon to be reached; an intermittent buzzer sounds. Lights up to indicate that the preset torque has been reached; a continuous buzzer sounds.
- ⑦ LCD display: Displays various data.
- ⑧ USB terminal: For battery charging and data outputting (Windows only).

Model	Range	Increment	Total length mm	Dimensions (mm)					Weight kg	Accessory			
				Head			Body						
				ϕD_1	L ₁	L ₂	A	B	ϕC	ϕC_1	ϕE		
DLT-N50-UC	10.00~50.00 N·m	0.01 N·m	411	12	55	15	47	47	37	40	27.2	0.8	50QCK
	7.38~36.87 ft·lb	0.01 ft·lb											
	88.5~442.5 in·lb	0.1 in·lb											
	102.0~509.8 kgf·cm	0.1 kgf·cm											
DLT-N100-UC	20.0~100.0 N·m	0.1 N·m	413	15	65	17	47	47	37	40	27.2	0.9	100QCK
	14.8~73.8 ft·lb	0.1 ft·lb											
	177~885 in·lb	1 in·lb											
	2.04~10.19 kgf·m	0.01 kgf·m											
DLT-N200-UC	40.0~200.0 N·m	0.1 N·m	457	18	80	22	47	47	37	40	27.2	1	200QCK
	29.6~147.5 ft·lb	0.1 ft·lb											
	354~1770 in·lb	1 in·lb											
	4.08~20.38 kgf·m	0.01 kgf·m											

[Common Specifications for DLT-N Series]

Accuracy	Data memory	Measurement mode	Alarm mode	Measurement method	Power source	Use time	Charge time	Auto power off	I/O terminal	Operating temperature range
$\pm 1\% + 1$ digit ($\pm 3\% + 1$ digit for DLT-N50)	999 data	RUN, PA, PC	LED and buzzer	CW/CCW auto switching	Ni-MH rechargeable batteries, size AA, 1.2V; 2 pieces	Approx. 20 hours with fully charged batteries (continuous use)	Max 5 hours. (approx.) for discharge and charge	After 60 seconds	USB terminal (for Windows) for data outputting and battery charging	+5 ~ +35°C

RUN : Current load value is shown continuously PA : The first peak value is detected and held. PC : Peak-to-peak and auto start

FK INDICATOR PLATE TORQUE WRENCHES

Quite suitable for general tightening and for checking torque on previously tightened joints. A popular series with fan-shaped indicator plate scales.

FEATURES

- The simple structure and small friction area give this series of tools a long life.
- Strong and easy to handle.
- Accuracy : $\pm 3\%$ of indicated value over the full range

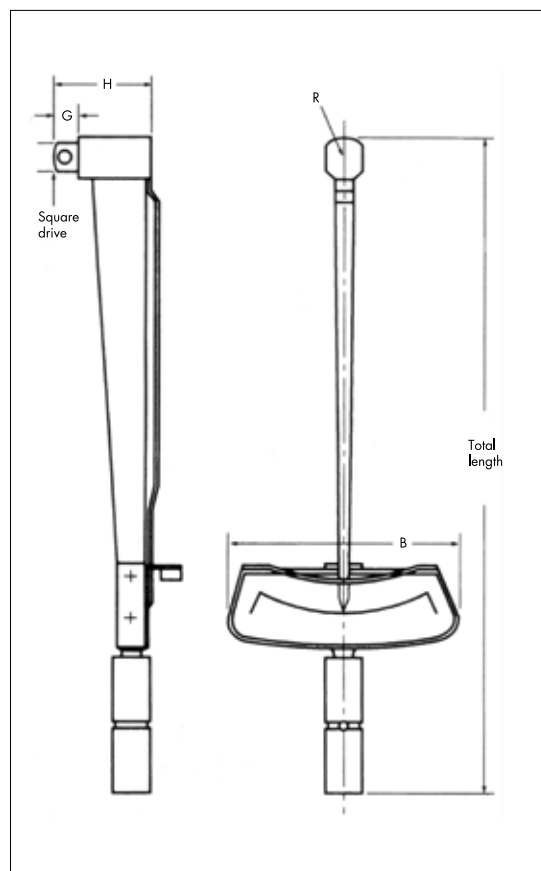

Model (kgf·cm)	Range (CW/CCW) kgf·cm	Increment	Old Model (N·m)	New Model (N·m)	Range (CW/CCW) cN·m/N·m	Increment	Sq. drive mm	Total length mm	Dimensions (mm)					Weight kg	
									Head			Body B			
									H	G	R				
4FK	1~4	0.2	N4FK	CN40FK	10~40 cN·m	2 cN·m	6.35 (1/4")	110	26	7.5	5	54	0.05		
7FK	1~7	0.2	N7FK	CN70FK	10~70 "	2 "		132							
15FK	5~15	0.5	N15FK	CN150FK	50~150 "	5 "		140							
30FK	10~30	1	N30FK	N3FK	1~3 N·m	0.1 N·m		170						32	0.1
60FK	10~60	2	N60FK	N6FK	1~6 "	0.2 "		190						36.5	0.22
120FK	20~120	5	N120FK	N12FK	2~12 "	0.5 "		237						43.5	0.25
230FK	30~230	5	N230FK	N23FK	3~23 "	0.5 "	9.53 (3/8")	290	42	11	9	106	0.3		
450FK	50~450	10	N450FK	N45FK	5~45 "	1 "	320								
900FK	100~900	20	N900FK	N90FK	10~90 "	2 "	12.7 (1/2")	388	58	14	12.5	114	1.1		
1300FK	200~1,300	20	N1300FK	N130FK	20~130 "	2 "		441							
1800FK	300~1,800	50	N1800FK	N180FK	30~180 "	5 "		487							
2800FK	500~2,800	50	N2800FK	N280FK	50~280 "	5 "	19.05 (3/4")	587	82	20	15	124	2.6		
4200FK	700~4,200	100	N4200FK	N420FK	70~420 "	10 "		853							
5600FK	1,000~5,600	100	N5600FK	N560FK	100~560 "	10 "		946						48	28
7000FK	1,000~7,000	100	N7000FK	N700FK	100~700 "	10 "	1,172	51	31	4.4					
8500FK	1,500~8,500	200	N8500FK	N850FK	150~850 "	20 "	25.4 (1")	1,387	76.5	27	37	241	8.0		
10000FK	2,000~10,000	200	N10000FK	N1000FK	200~1,000 "	20 "		1,578							
15000FK	3,000~15,000	200	N15000FK	N1500FK	300~1,500 "	20 "		1,973						43	13.3
														50	17.0

* is the new model that is applied from 1st January, 2016.

TOK-G DIAL INDICATOR TORQUE WRENCHES

Easy to read dial indicator. Well suited for inspection and general maintenance service.



TOK-G (with peak indicator)



FEATURES

- Oval design with comfort rubber grip reduces strain.
- Easily readable for inspections.
- Useful for general tightening work.
- Accuracy : $\pm 3\%$ of indicated value over the full range

USING A TOK WRENCH

- (1) Turn the dial cap and set the indicator to 0.
 - (2) Mount a socket on the square drive.
 - (3) Tighten until the indicator points to the desired torque.
- * When using a peak indicator wrench, set it to 0 before tightening.

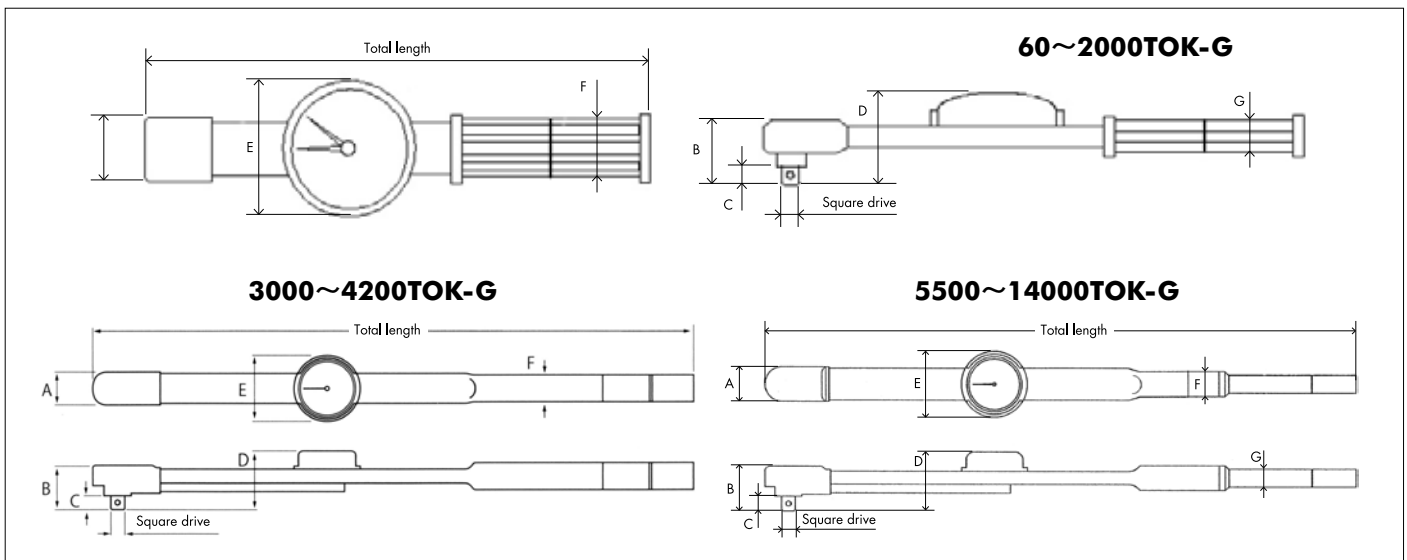

* 14000TOK-G and N1400TOK-G do not have the rubber head.

Model (kgf·cm/kgf·m)	Range (CW/CCW)	Increment	Model (N·m)	Range (CW/CCW)	Increment	Square drive	Total length	Dimensions (mm)							Weight kg
								Head			Body				
								A	B	C	D	E	F	G	
60TOK-G	6~60 kgf·cm	1 kgf·cm	N 6TOK-G	0.6~6	0.1	6.35 (1/4")	260	35	38.5	7.5	58	90	37	21.5	0.5
120TOK-G	10~120 //	2 //	N 12TOK-G	1~12	0.2										
300TOK-G	50~300 //	5 //	N 30TOK-G	5~30	0.5										
500TOK-G	50~500 //	5 //	N 50TOK-G	5~50	0.5	9.53 (3/8")	323	35	43	11	60	90	37	21.5	0.61
700TOK-G	100~700 //	10 //	N 70TOK-G	10~70	1										
1400TOK-G	200~1,400 //	20 //	N 140TOK-G	20~140	2	12.7 (1/2")	463	39	49	14	65	90	41	22.5	0.87
2000TOK-G	200~2,000 //	20 //	N 200TOK-G	20~200	2										
3000TOK-G	3~30 kgf·m	0.5 kgf·m	N 300TOK-G	30~300	5	19.05 (3/4")	682	41	55	20	77	90	φ30	φ30	1.6
4200TOK-G	4~42 //	1 //	N 420TOK-G	40~420	10										
5500TOK-G	5~55 //	1 //	N 550TOK-G	50~550	10										
7000TOK-G	7~70 //	1 //	N 700TOK-G	70~700	10										
8500TOK-G	10~85 //	1 //	N 850TOK-G	100~850	10	25.4 (1")	1,384	58	72	27	93	90	φ45	φ34	7.1
10000TOK-G	10~100 //	2 //	N 1000TOK-G	100~1,000	20										
14000TOK-G	20~140 //	2 //	N 1400TOK-G	200~1,400	20										

LTDK CLUTCH RELEASE TORQUE SCREW DRIVERS

Clutch release prevents over-tightening, reduces fatigue.

FEATURES

- Comfortable grip for extended use.
- Light weight and short overall length facilitates jobs.
Sensitive clutch release helps the operator feel when the torque setting is reached.
- Set the required torque value and tighten, all operators tighten consistently.
- Two Phillips bit are included.
- Various hex and box drive bits are available.
- Use for both clockwise and counter-clockwise tightening.
- Accuracy : $\pm 3\%$ of indicated value over the full range, clockwise.
- "H"-models accept standard bits instead of CB type bits.

USING AN LTDK DRIVER

- (1) Select and mount a bit to match the fastener.
- (2) Rotate the adjusting ring and set the desired torque.
- (3) Tighten the fastener clockwise until the clutch releases and there is no more resistance.



CN60~CN500LTDK

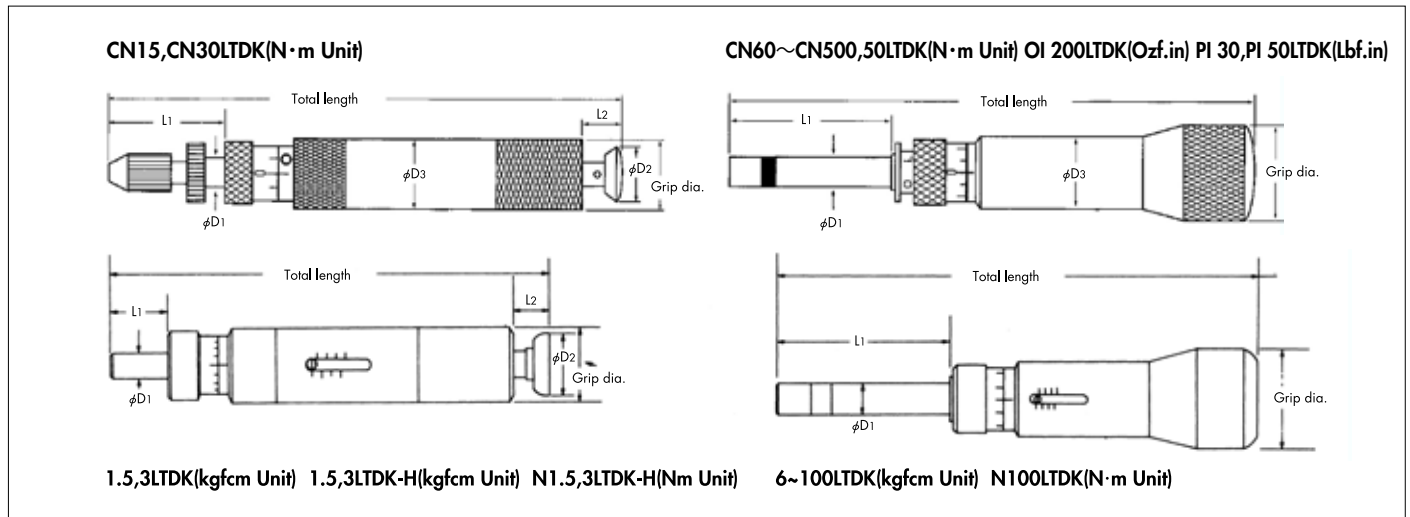

Old Model (cN·m/N·m)	New Model (cN·m/N·m)	Range	Increment	Model (ozf·in/lbf·in)	Range	Increment	Grip dia.	Total length (without bit)	Dimensions (mm)					Weight	Included Accessory		
									cN·m/N·m		ozf·in/lbf·in		Body				
							φmm	mm	L1	L2	φD1	φD2	φD3	g	Phillips	Bit type	
N1.5LTDK	CN15LTDK	1 ~ 15 cN·m	0.1 cN·m				16	107	22	10.5	5.5	14.4	16	57	No.0 No.1	KANON bits CB type	
N3LTDK	CN30LTDK	2 ~ 30 "	0.2 "				25	110	26				20	99	No.0 No.1		
N6LTDK	CN60LTDK	5 ~ 60 "	0.5 "				30						192		No.0 No.1	Standard bits SB type	Included
N12LTDK	CN120LTDK	20 ~ 120 "	1 "	OI 200LTDK	40 ~ 200 ozf·in	1	34	157	51		10		25	214	No.1 No.2		
N20LTDK	CN200LTDK	40 ~ 200 "	1 "	PI 30LTDK	4 ~ 30 lbf·in	0.1	40	200	63				34	436	No.2 No.3		
N30LTDK	CN300LTDK	40 ~ 300 "	1 "	PI 50LTDK	10 ~ 50 "	0.25	45	235	100		11		762	No.2, No.3			
N50LTDK	CN500LTDK	100 ~ 500 "	2.5 "				45	235	100		11		762	No.2, No.3			
N100LTDK	N10LTDK	4 ~ 10 N·m	0.05 N·m				45	235	100		11		762	No.2, No.3			
N1.5LTDK-H	CN15LTDK-H	1 ~ 15 cN·m	0.1 cN·m				16	111	26	9	10	14.4	35	60	No.0 No.1		
N3LTDK-H	CN30LTDK-H	2 ~ 30 "	0.2 "														

* is the new model that is applied from 1st January, 2016.

Model (kgf·cm)	Range	Increment	Grip dia.	Total length (without bit)	Dimensions (mm)					Weight	Included Accessory		
					Body						Bits		Extension Bar
					L1	L2	φD1	φD2	φD3		g	Phillips	
1.5LTDK	0.1~1.5 kgf·cm	0.01 kgf·cm	16	99	14	9	5.5	14.4		50	No.0 No.1	KANON bits OB type	
3LTDK	0.2~3 //	0.02 //											
6LTDK	0.5~6 //	0.05 //	25	110	35				20	95	No.0 No.1	Standard bits SB type	
12LTDK	2~12 //	0.1 //											
20LTDK	4~20 //	0.1 //	34	157	57				25	190	No.0 No.1	Standard bits SB type	
30LTDK	4~30 //	0.1 //											
50LTDK	10~50 //	0.25 //	40	200	73				34	436	No.1 No.2	Standard bits SB type	
100LTDK	40~100 //	0.5 //											
1.5LTDK-H	0.1~1.5 //	0.01 //	16	111	26	9	10	14.4	35	762	No.2, No.3	Standard bits SB type	Included
3LTDK-H	0.2~3 //	0.02 //											

STDK PRE-SET TORQUE DRIVERS

Clutch release prevents over tightening.



FEATURES

- A single function driver, used for a single torque setting.
 - Most suited for tightening multiple same-size fasteners at the same torque in a production line.
 - Setting confirmation unnecessary.
 - Light weight and short overall length facilitates jobs.
Sensitive clutch release helps the operator feel when the torque setting is reached.
 - All operators tighten consistently.
 - Two Phillips bit are included.
 - Various hex and box drive bits are available.
 - Accuracy : ±3% of set value, clockwise.
- * Please specify required set torque when you order.

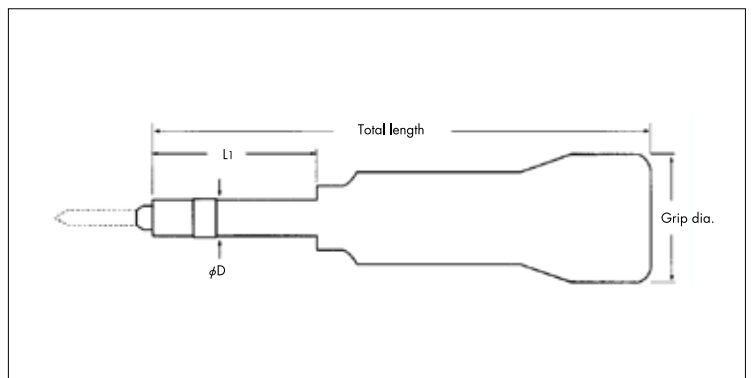

Model (kgf·cm)	Range	Old Model (cN·m/N·m)	New Model (cN·m/N·m)	Range	Model (ozf·in/lbf·in)	Range	Grip dia.	Total length (without bit)	Dimensions (mm)		Weight	Included Accessory		
									Body			Bits		Extension Bar
									cN·m/N·m	ozf·in/lbf·in		φ mm	mm	
1.5STDK	0.1~1.5	N1.5STDK	CN15STDK	1~15 cN·m	Ol 22STDK	2~22 ozf·in	16	92	22	8	45	No.0 No.1	KANON bits CB type	
3STDK	0.2~3	N3STDK	CN30STDK	2~30 //	Ol 44STDK	4~44 //								
6STDK	0.5~6	N6STDK	CN60STDK	5~60 //	Ol 80STDK	20~80 //	25	103	41	10	94	No.0 No.1	Standard bits SB type	
12STDK	2~12	N12STDK	CN120STDK	20~120 //	Ol 200STDK	40~200 //								
20STDK	4~20	N20STDK	CN200STDK	40~200 //	Pl 20STDK	4~20 lbf·in	30	116	54	30	148	No.0 No.1	Standard bits SB type	
30STDK	4~30	N30STDK	CN300STDK	40~300 //	Pl 30STDK	4~30 //								
50STDK	10~50	N50STDK	CN500STDK	100~500 //	Pl 50STDK	10~50 //	35	117	54	35	170	No.1 No.2	Standard bits SB type	Included
100STDK	40~100	N100STDK	CN100STDK	4~10 N·m	Pl 100STDK	40~100 //								

* is the new model that is applied from 1st January, 2016.

DPSK DIAL GAUGE TORQUE DRIVERS

Suited for light torque, general tightening work, inspections. Easy to handle, easy to read scale.

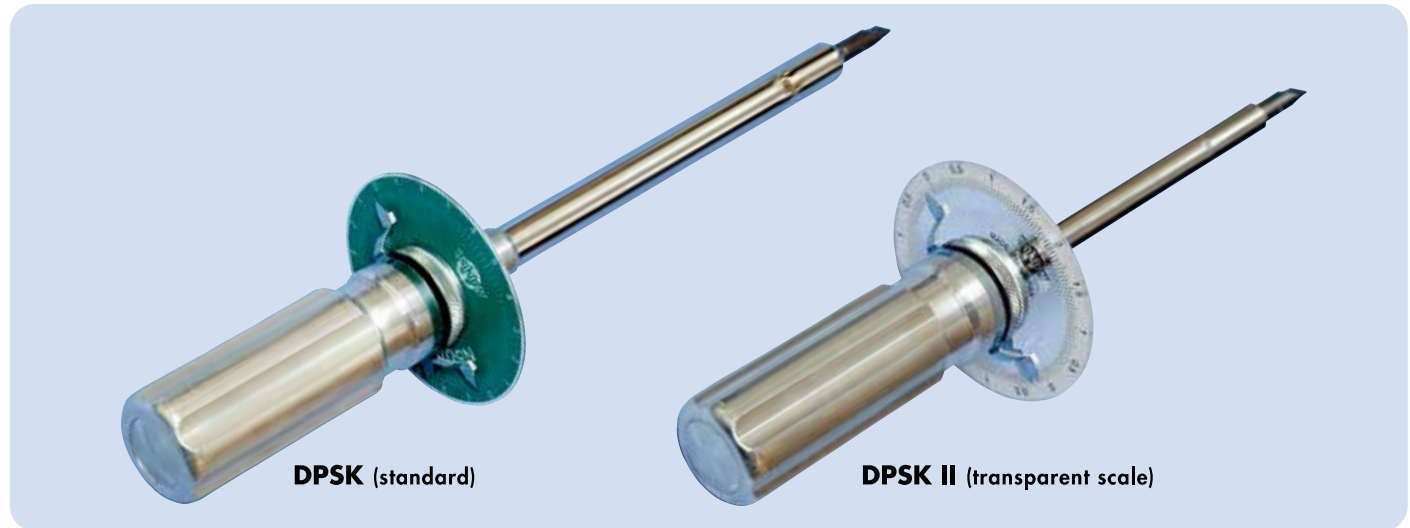

FEATURES

DPSK (standard)

- A light torque driver well suited for general tightening, inspections and break tests.
- Easy handling with a direct reading dial gauge.
- Use for both clockwise and counterclockwise tightening.
- Peak torque indicator works in both directions, too.
- Large, easily read dial gauge.

DPSK II (transparent scale)

- The transparent scale makes engaging the fastener easier.
- For both models, accuracy is $\pm 3\%$ of the indicated value over the full range

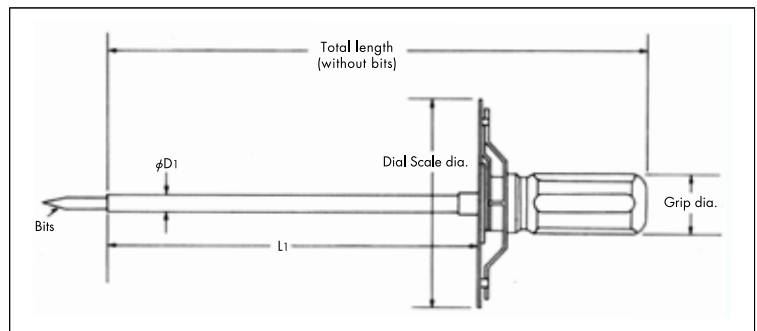

USING A DPSK DRIVER

- (1) Mount a bit matching the fastener being
- (2) Loosen the peak indicator ring.
- (3) Set the peak indicator to 0.
- (4) Tighten the fastener while observing the scale.

Model (kgf·cm)	Range (CW/CCW)	Increment	Old Model (cN·m/N·m)	New Model (cN·m/N·m)	Range (CW/CCW)	Increment	Dial dia.	Grip dia.	Total length (without bit)	Dimensions (mm)		Weight	Included Accessory Bits			
										Driver shaft(mm)	Weight		Phillips	Bit type		
1DPSK	0.2~1	0.025	N 1DPSK	CN 10DPSK	2~10 cN·m	0.25 cN·m	78	22	217	152	6	0.075	No.0 No.1	KANON bits OB type		
2DPSK	0.5~2	0.05	N 2DPSK	CN 20DPSK	5~20 "	0.5 "			195	130						
5DPSK	1~5	0.2	N 5DPSK	CN 50DPSK	10~50 "	2 "			208	143						
10DPSK	2~10	0.2	N 10DPSK	CN 100DPSK	20~100 "	2 "			222	130					12	0.33
20DPSK	5~20	0.5	N 20DPSK	CN 200DPSK	0.5~2 N·m	0.05 N·m	78	33	242	130	12	0.36	No.1 No.2	Standard bits SB type		
50DPSK	10~50	2	N 50DPSK	CN 500DPSK	1~5 "	0.2 "			300	188					14	0.47
10DPSK(II)	2~10	0.2	N 10DPSK(II)	CN 100DPSK-L	20~100 cN·m	2 cN·m			222	130					12	0.29
20DPSK(II)	5~20	0.5	N 20DPSK(II)	CN 200DPSK-L	0.5~2 N·m	0.05 N·m			242	130					12	0.32
50DPSK(II)	10~50	2	N 50DPSK(II)	CN 500DPSK-L	1~5 "	0.2 "	300	188	14	0.42						

* is the new model that is applied from 1st January, 2016.

SGK TORQUE GAUGES

Capable of accurately measuring very low torque values.

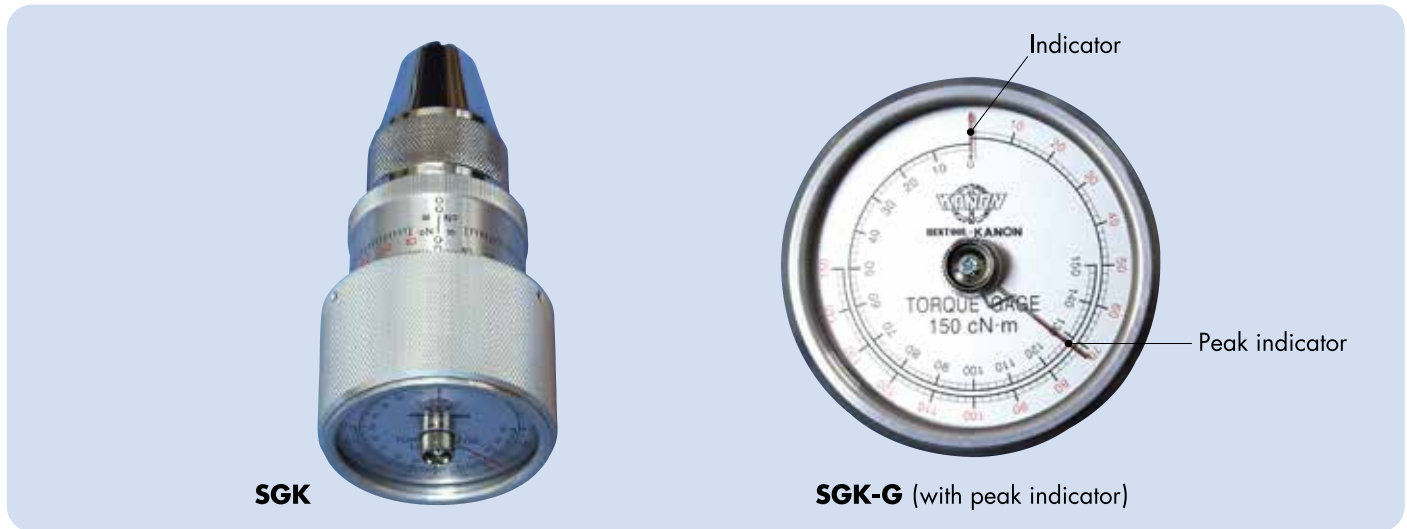

* Peak indicator is optional

FEATURES

- Due to their miniature design and light weight, these gauges are convenient and easy to carry.
- A three part chuck with knurled surface enables firmly gripping even odd shapes.
- The inset scale face helps avoid incidental damage.
- The gauges measure clockwise and counterclockwise.
- With scales on the sides and the face, torque readings can be obtained either way.
- Accuracy : $\pm 3\%$ of the indicated value over the full range

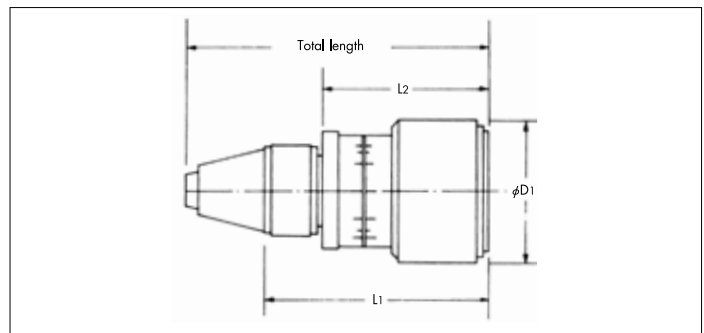

USING AN SGK GAUGE

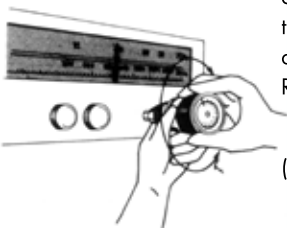

Starting torque can be measured with the chuck gripping a knob or shaft of an electronic device.
 Rotate clockwise or counterclockwise.

(Rotate CW or CCW)



- If you would like SGK with a peak indicator, please specify "SGK-G" on your purchase order.
 ex) N150(I)SGK-G

Three part chuck

Model (gf·cm/kgf·cm)	Range (CW/CCW) gf·cm/kgf·cm	Increment	Old Model (mN·m/cN·m)	New Model (mN·m/cN·m)	Range (CW/CCW) mN·m/cN·m	Increment	Chucking dia. φ mm	Total length mm	Dimensions (mm)			Weight kg
									Grip dia. φD1	Total length (without chuck) L1	L2	
90(I)SGK	10 ~ 90	2	N90(I)SGK	MN95GK	1 ~ 9	0.2	1 ~ 6.5	106	43	81	57.5	0.29
150(I)SGK	20 ~ 150	2	N150(I)SGK	MN155GK	2 ~ 15	0.2						
300(I)SGK	40 ~ 300	5	N300(I)SGK	MN305GK	4 ~ 30	0.5						
600(I)SGK	50 ~ 600	10	N600(I)SGK	MN605GK	5 ~ 60	1						
1200(I)SGK	100 ~ 1,200	20	N1200(I)SGK	MN1205GK	10 ~ 120	2						
2400(I)SGK	200 ~ 2,400	50	N2400(I)SGK	MN2405GK	20 ~ 240	5						
1.5(II)SGK	0.1 ~ 1.5	0.02	N1.5(II)SGK	CN155GK	1 ~ 15	0.2	1 ~ 8.5	134	63	100	73	0.6
2.4(II)SGK	0.2 ~ 2.4	0.02	N2.4(II)SGK	CN245GK	2 ~ 24	0.2						
3.6(II)SGK	0.4 ~ 3.6	0.05	N3.6(II)SGK	CN365GK	4 ~ 36	0.5						
6(II)SGK	0.5 ~ 6	0.1	N6(II)SGK	CN605GK	5 ~ 60	1						
9(II)SGK	1 ~ 9	0.2	N9(II)SGK	CN905GK	10 ~ 90	2						
15(II)SGK	1 ~ 15	0.2	N15(II)SGK	CN1505GK	10 ~ 150	2						

* is the new model that is applied from 1st January, 2016.

KDTA-SV DIGITAL TORQUE ANALYZERS

Enhanced digital processor system. Provides high performance with digital wrenches.

FEATURES

- LED display eliminates reading errors.
- Processor chip assures measurement with high reliability and accuracy.
- The display unit angle can be adjusted approximately 90°.
- Can be connected to various optional equipment (printer, personal computer, external input keyboard).
- Saves time and helps speed up work.
- Equipped with a kgf-cm/N·m selector switch.
- Operator can set min/max percentage parameters from 0–10%.
- Analyzer can indicate in or out of specification with a green or red lamp respectively.

SPECIFICATIONS

- Power source : AC100-240V 50/60Hz
- Accuracy : ±1% of the indicated value +1 increment, over the full range
- Display : red LED (character height : 25mm)
- Operating temperature : 0~40°C



KDTA-2000SV

Model	Range(CW/CCW)		English Model	Range(CW/CCW)		Measuring mode	Unit conversion	Dimensions (mm)			Drive size mm	Weight kg	Included Accessory
	kgf-cm/kgf-m	N·m		lbf-in	N·m			Overall depth	Overall width	Overall height			
KDTA-20SV	2~20 kgf-cm	0.01 kgf-cm	KDTA-20SV	1.77~17.36 lbf-in	0.01 lbf-in	RUN Peak hold Peak to peak hold	Standard kgf-cm N·m English Model lb-in N·m	120	250	240	12	6	6.35×12 9.5×12 Socket
	20~200 cN·m	0.1 cN·m		20~200 cN·m	0.1 cN·m								
KDTA-100SV	10~100 kgf-cm	0.1 kgf-cm	KDTA-100SV	8.9~86.8 lbf-in	0.1 lbf-in								
	1~10 N·m	0.01 N·m		1~10 N·m	0.01 N·m								
KDTA-200SV	20~200 kgf-cm	0.1 kgf-cm	KDTA-200SV	17.7~173.6 lbf-in	0.1 lbf-in								
	2~20 N·m	0.01 N·m		2~20 N·m	0.01 N·m								
KDTA-1000SV	100~1000 kgf-cm	1 kgf-cm	KDTA-1000SV	89~868 lbf-in	1 lbf-in								
	10~100 N·m	0.1 N·m		10~100 N·m	0.1 N·m								
KDTA-2000SV	200~2000 kgf-cm	1 kgf-cm	KDTA-2000SV	177~1736 lbf-in	1 lbf-in								
	20~200 N·m	0.1 N·m		20~200 N·m	0.1 N·m								
KDTA-6000SV	600~6000 kgf-cm	1 kgf-cm											
	60~600 N·m	0.1 N·m											
KDTA-10000SV	10~100 kgf-m	0.1 kgf-m											
	100~1000 N·m	1 N·m											

DRIVE ATTACHMENTS (Optional)

■ KDTA-20SV/100SV/200SV 200SVH



■ KDTA-1000SV/2000SV 1000SVH/2000SVH, 2000SV II



■ KDTA-3000SVH



KDTA-SVH **LARGE DIGITAL TORQUE ANALYZERS**



FEATURES

- LED display eliminates reading errors.
- Processor chip assures measurement with high reliability and accuracy.
- The display unit angle can be adjusted approximately 90°.
- Can be connected to various optional equipment (printer, personal computer, external input keyboard).
- Saves time and helps speed up work.
- Equipped with a kgf-cm/N-m selector switch.

SPECIFICATIONS

- Power : AC100-240V 50/60Hz
- Accuracy : ±1% of the indicated value +1 increment, over the full range
- Display : red LED (character height : 25mm)
- Operating temperature range : 0~40°C

Model	Range(CW/CCW)	Increment	English Model	Range(CW/CCW)	Increment	Measuring mode	Unit conversion	Drive size	Weight	Included Accessory
	kgf-cm/kgf-m	N-m		lbf-in/lbf-ft	N-m			mm	kg	
KDTA-200SVH	20~200 kgf-cm	0.1 kgf-cm	KDTA-200SVH	17.7~177.0 lbf-in	0.1 lbf-in	RUN Peak hold Peak to peak hold	Standard kgf-cm N-m	12	10	6.35×12 Socket 9.5×12 Socket
	2~20 N-m	0.01 N-m		2~20 N-m	0.01 N-m					
KDTA-1000SVH	100~1000 kgf-cm	1 kgf-cm	KDTA-1000SVH	89~885 lbf-in	1 lbf-in		English Model lb-in N-m	14	18	9.5×14 Socket 12.7×14 Socket
	10~100 N-m	0.1 N-m		10~100 N-m	0.1 N-m					
KDTA-2000SVH	200~2000 kgf-cm	1 kgf-cm	KDTA-2000SVH	177~1770 lbf-in	1 lbf-in		Standard kgf-cm N-m	22	29	12.7×22 Socket 19.05×22 Socket
	20~200 N-m	0.1 N-m		20~200 N-m	0.1 N-m					
KDTA-3000SVH	300~3000 kgf-cm	1 kgf-cm	KDTA-3000SVH	22.1~221.2 lbf-ft	0.1 lbf-ft	English Model lb-ft N-m	26	80	12.7×26 Socket 19.05×26 Socket	
	30~300 N-m	0.1 N-m		30~300 N-m	0.1 N-m					
KDTA-6000SVH	600~6000 kgf-cm	1 kgf-cm	KDTA-6000SVH	44.2~442.5 lbf-ft	0.1 lbf-ft	English Model lb-ft N-m	30	65	12.7×30, 19.05×30 25.4×30 Socket	
	60~600 N-m	0.1 N-m		60~600 N-m	0.1 N-m					
KDTA10000SVH	10~100 kgf-m	0.1 kgf-m	KDTA-10000SVH	74~737 lbf-ft	1 lbf-ft					
	100~1000 N-m	1 N-m		100~1000 N-m	1 N-m					

TPK-3 **STANDARD PRINTER**

FEATURES

- Indicates in or out of specification on the led display and print out.
- * Printer cables are options. CR-1 is for DTC-REV series.
 CSV-1 is for KDTA-SV and KDTA-SVH series.



DRT KANON TORQUE MEASUREMENT MULTI-INDICATOR

Model DRT multi-indicator handles 16 different types of work.
 The TEDS-based smart indicator is designed for accurate and speedy analysis of bolt-tightening.

FEATURES

- Tools are easily exchanged and calibrated. A sensor with built-in TEDS information is directly connected to a tool for automatic reading of necessary information, eliminating troublesome calibration each time a tool is exchanged (IEEE 1451.4, Class 2 mixed mode interfaced).
- Various tools can be used, including click type and non-click type torque wrench and strain gauge sensors.
- Torque values remain in waveforms, allowing the user to view torque in any desired place.
- Bolt-tightening is analyzed in a short time: Tightening, Loosening inspection, Re-tightening inspection, Torque wrench inspection, Destructive inspection

TEDS-based multi-indicating system (Examples)

Torque wrench with sensor for operation



Torque sensor



Torque wrench with sensor for inspection



* Sensors are built to order.

Multi-indicator DRT



Data collection

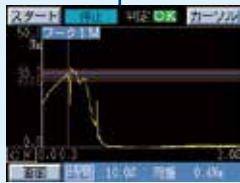

Torque is displayed in waveforms.



Judgment (an example of pass)



Judgment (an example of rejection)

* English version is also available

<Specifications>

Model	DRT	
Display/controller	3.5 type STN color LCD (320 x 240 dots)	
	Controller	Touch panel
	Display range	0 to ±9999
	Decimal point position	Arbitrarily selected
	Display change frequency	3 times/s
	Time axis	0.1 to 99.9s
Operation screen	Digital load display screen, waveform display screen, setting screen, strain display.	
Setting	Comparative judgment values	
Function	Load value: upper limit, lower limit, upper-upper limit, and lower-lower limit	
	Hold function	Inflection point, sample, peak, maximal and minimal hold
	Clock function	Data is controlled and saved according to real-time clock.
Data output	RS-232C, CF card	
Power supply	AC 100 to 240V	
Operating temperature range	0 to +40°C	
Weight	2.8kg	
Dimensions	107 (W) x 140 (H) x 257 (D) mm	
Applicable standards	EMC	VCCI 1 (Class A), EN55011 (Class A), EN61326-4-2, 3, 4, 5, 6, 8, 11, EN61000-3-2, 3
	Safety standards	EN61010-1





Click type torque wrench for DRT

Model	Range
DRT-N50DR	10 ~ 50Nm
DRT-N100DR	20 ~ 100Nm
DRT-N200DR	40 ~ 200Nm



Non-click torque wrench for DRT

Model	Range
DRT-N40DTC	4 ~ 40Nm
DRT-N100DTC	10 ~ 100Nm
DRT-N200DTC	40 ~ 200Nm



Torque Driver for DRT

Model	Range
DRT-CN500LTDK	100 ~ 500cNm



Load cell for DRT

Model	Range
DRT-N25V	0.2 ~ 2Nm
DRT-N205V	2 ~ 20Nm
DRT-N2005V	20 ~ 200Nm

KDTA-SVS **DIGITAL TORQUE ANALYZERS**

Highly accurate and economical torque analyzer, easy for operators to use on the job site.



FEATURES

- LED display eliminates reading errors.
- Processor chip assures measurement with high reliability and accuracy.
- Connects to an optional printer.
- Saves time and helps speed up work.
- Equipped with a kgf·cm/N·m selector switch.

SPECIFICATIONS

- Power : AC100-240V 50/60Hz
- Accuracy : $\pm 1\%$ of the indicated value +1 increment, over the full range
- Display : Red LED (character height : 25mm)
- Operating temperature range : 0~40°C

Old Model	New Model	Torque measuring range	Increment	Old English Model	New Model	Torque measuring range	Increment	Drive size	Weight (kg)
KDTA-2000SV (II)	KDTA-2000SVS	50 ~ 2000kgf·cm/5 ~ 200N·m	1kgf·cm ~ 0.1N·m	KDTA-2000SV (II)	KDTA-2000SVS	35 ~ 1770lb·in/5 ~ 200N·m	1lb·in ~ 0.1N·m	14mm	11.5

KDTA-DH

DIGITAL TORQUE ANALYZERS FOR TORQUE DRIVERS



KDTA-8DH

KDTA-8DH / KDTA-80DH

FEATURES

- Designed for LTKD and STDK
- Battery powered
- Battery Charger is available for AC 100V~240V 50/60Hz
- Lightweight plastic case
- kgf·cm/N·m / lbf·in unit conversion
- MODE : RUN (constantly indicates torque value.)
 PEAK HOLD
 PEAK TO PEAK-HOLD
- AUTO RESET : Timer function available
- DATA OUTPUT : Digital output
- PRINTER : TPK-3 (Optional)
- Accuracy : ±1% of the indicated value +1 increment, over the full range

Model	Range	Increment	Measuring mode	Battery	Size	Weight (kg)
KDTA-8DH	3~800mN·m 0.3~80cN·m 0.03~8kgf·cm 0.03~7lbf·in	0.1mN·m 0.01cN·m 0.001kgf·cm 0.001lbf·in	RUN Peak hold Peak to Peak hold	Rechargeable	230 (W) ×123 (D) ×65 (H) mm	1.8
KDTA-80DH	3~800cN·m 0.03~8N·m 0.3~80kgf·cm 0.3~70lbf·in	0.1cN·m 0.0001N·m 0.01kgf·cm 0.01lbf·in	RUN Peak hold Peak to Peak hold	Rechargeable	230 (W) ×123 (D) ×65 (H) mm	1.8

KDTA-D

DIGITAL TORQUE ANALYZERS FOR ELECTRIC DRIVERS

KDTA-10D / KDTA-100D

FEATURES

- Battery is rechargeable.
- For any brand of the Electric Driver
- Battery Charger is available for AC 100V~240V 50/60Hz
- MODE : RUN (constantly indicates torque value.)
 PEAK HOLD
 PEAK TO PEAK-HOLD
- AUTO RESET : Timer function available
- DATA OUTPUT : Digital output
- PRINTER : TPK-3 (Optional)
- Accuracy : ±1% of the indicated value +1 increment, over the full range



Model	Range	Increment	Measuring mode	Battery	Size	Weight (kg)
KDTA-10D	1.5~100.0cN·m 0.15~10.00kgf·cm 0.13~10.00lbf·in	0.1cN·m 0.01kgf·cm 0.01lbf·in	RUN Peak hold Peak to Peak hold	Rechargeable	230 (W) ×123 (D) ×65 (H) mm	1.18
KDTA-100D	15~1000cN·m 1.5~100.0kgf·cm 1.3~100.0lbf·in	1cN·m 0.1kgf·cm 0.1lbf·in	RUN Peak hold Peak to Peak hold	Rechargeable	230 (W) ×123 (D) ×65 (H) mm	1.18

MLQK MARKING TORQUE WRENCHES

No tightening negligence with marking check.

FEATURES

- To click torque wrench and the bolt is painted.
No marking without click.
- 6000 times can be marked with 14 to 24mm socket.
- 1500 times can be marked with 8 to 13mm socket.
- Easy maintenance.
- Accuracy : $\pm 3\%$
- Please select the size of socket when you order MLQK.
Socket is modified for MLQK



MLQK

* Ink is not included

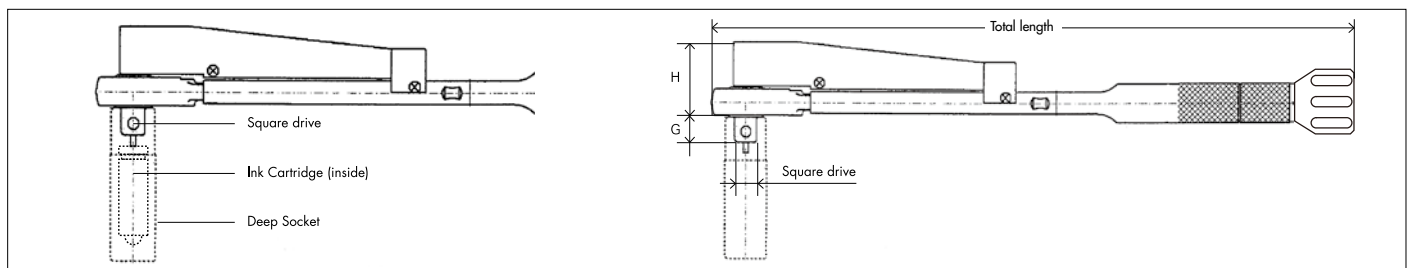

Model (kgf·cm)	Range	Increment	Old Model (N·m)	New Model (N·m)	Range	Increment	Square drive	Total length	Dimensions (mm)			Weight	Optional socket
	kgf·cm				N·m				Head		H		
250MLQK	70~250	2	N250MLQK	N25MLQK	7~25	0.2	9.53	232	54	11	0.38	8~24	
500MLQK	100~500	5	N500MLQK	N50MLQK	10~50	0.5	(3/8")	257	54	11	0.57	8~24	
1000MLQK	200~1,000	10	N1000MLQK	N100MLQK	20~100	1	12.7	359	57	14	0.91	13~24	
1400MLQK	400~1,400	10	N1400MLQK	N140MLQK	40~140	1	(1/2")	399	57	14	0.96	13~24	

MLQK-E HEXAGON MARKING TORQUE WRENCHES

No tightening negligence with marking check.

FEATURES

- A mark is automatically painted when the specified torque is reached; an electric signal is triggered to pop up the paint marker at the tip of the wrench to mark.
- Marking position is finely adjustable front to back and side to side. Marks can also be printed on the side of a socket bolt, or the head or periphery of a buried bolt.

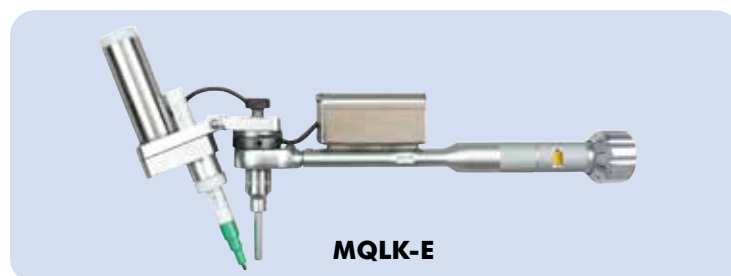

MLQK-E

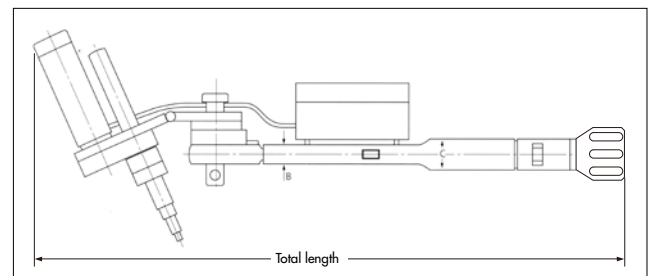

BATTERY CHARGER SPECIFICATIONS

- Input : 100-240VAC, 50/60Hz
- Cell : 2S and 3S
- Output current : 3 x 850mA



Model (kgf·cm)	Range	Increment	Old Model (N·m)	New Model (N·m)	Range	Increment	Square drive	Total length	Dimensions (mm)			Weight
	kgf·cm				N·m				B	C	kg	
60MLQK-E	20~60	1	N60MLQK-E	N6MLQK-E	2~6	0.1						0.7
120MLQK-E	40~120	2	N120MLQK-E	N12MLQK-E	4~12	0.2	9.53	327	10	15		0.8
250MLQK-E	70~250	2	N250MLQK-E	N25MLQK-E	7~25	0.2	(3/8")					
500MLQK-E	100~500	5	N500MLQK-E	N50MLQK-E	10~50	0.5		352		20		1
1000MLQK-E	200~1000	10	N1000MLQK-E	N100MLQK-E	20~100	1	12.7	459	12	22		1.3
1400MLQK-E	400~1400	10	N1400MLQK-E	N140MLQK-E	40~140	1	(1/2")	499				1.4

* is the new model that is applied from 1st January, 2016.

TCSK-99MA

MULTI-FUNCTION TORQUE TASK MANAGER / ANALYZER

The multi-controller, the "Careless Mistake Detector" has a 100-240V multi-input type power system.

SWPMSeries

TORQUE TOOLS FOR TCSK

SWP tools connect with TCSK-99MA and prevent missing tightening joints.

TCSK-99MA



N-QLK-SWPM

This is an extremely useful multi-function controller that can serve many purposes, such as detecting loose joints, eliminating faulty fastener tightening, and task time management through connection with a KANON torque wrench, or torque driver.

FEATURES

- TCSK-99MA connects to KANON SWPM series torque tools.
- The red LED indicators are large and easy-to-read, allowing the operator to check the settings and progress of fastener tightening work at a glance. With visible and audible signals, the TCSK-99MA prevents you from leaving joints loose during fastener tightening work.
- Compared with conventional products, TCSK-99MA offers many different functions at a lower price.
- TCSK-99MA can help manage work processes via external output signals.

* This item does not have the CE mark.

Model	TCSK-99MA
Count	1 to 99
Timer setting	Digital input (set time for each function)
Judgement	OK (sounds and LED lights up in green) NG (sounds and LED lights up in red)
External input	Start, stop, reset, direction of rotation, work, lock
External output	Count OK, work NG/OK, overtime NG, in-time NG
Power supply	Input (primary side), switching power type multi-input of 100 to 240 VAC Output(secondary side) 24VDC, 2A 50W
Power consumption	10W
Outside dimensions	209mm (W)×77mm(H)×180mm(D)
Weight	approximately 1.7kg

FEATURES

- When the tool clicks, indicating the joint is tightened to the specified torque, a signal is sent to the TCSK-99MA.

SWPM TYPES ● Type and torque range

Model	Available Models
SPK-SWPM	190SPK~3100SPK N19SPK~N310SPK
RSPK-SWPM	190RSPK~3100RSPK N21RSPK~N320RSPK
QSPK-SWPM	PI60QSPK~PI2800QSPK 60QSPK~2800QSPK N6QSPK~N280QSPK
SPCK-SWPM	60SPCK~2800SPCK N6SPCK~N280SPCK

- Accuracy : ±3% of pre-set value

QLK-SWPM	PI60QLK~PI2000QLK 60QLK~2800QLK N6QLK~N280QLK
LCK-SWPM	60LCK~2800LCK N60LCK~N2800LCK

- Accuracy : ±3% of indicated value over the full range

LTDK-SWP	OI200LTDK / PI30LTDK~PI50LTDK 12LTDK~100LTDK CN120LTDK~N10LTDK
----------	--

- Accuracy : ±3% of indicated value over the full range, clockwise

* Torque wrench setting of N450QLK-SWPM less than 10N·m and 450QLK-SWPM less than 100kgf·cm does not go signal properly.

TK TENSION GAUGES

Demonstrating KANON's measuring versatility.
 Great performance whether measuring vertically or horizontally.

FEATURES

- Measures pushing, pulling force and spring tension.
 Our tension gauges are designed to indicate precise increments of force.
- Use the gauges for taking horizontal measurements. Just add the correcting value to the indicated value (see the table below). A peak indicator is available for TK500 to TK300 and TK500cN to TK3000cN.
- Accuracy : ± 1 increment

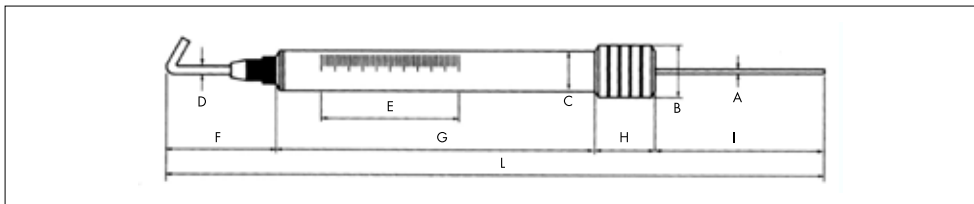

Model (g)	Range (g)	Incr. (g)	A mm	B mm	C mm	D mm	E mm	F mm	G mm	H mm	I mm	L mm	Weight (g)	Correcting value for horizontal measurements (g)
TK10	0 ~ 10	0.5	1.5	16	13	1.5	40	19	98	15	48	180	30	3
TK30	0 ~ 30	1	1.5	16	13	1.5	60	19	113	15	66	213	30	3
TK50	0 ~ 50	1	1.5	16	13	1.5	60	19	113	15	66	213	30	3
TK110	0 ~ 110	2	2	16	13	2	60	27.5	113	15	65.5	221	35	10
TK200	0 ~ 200	5	2	16	13	2	60	27.5	113	15	65.5	221	35	10
TK300	0 ~ 300	5	2	16	13	2	60	27.5	113	15	65.5	221	35	10
TK500	0 ~ 500	10	3	20	16	2.6	56	43	131	25	69	268	78	30
TK600	0 ~ 600	20	3	20	16	2.6	56	43	131	25	69	268	78	30
TK1000	0 ~ 1000	25	3	20	16	2.6	56	43	131	25	69	268	78	30
TK1500	0 ~ 1500	50	3	20	16	2.6	56	43	131	25	69	268	78	30
TK2000	0 ~ 2000	50	3	20	16	2.6	56	43	131	25	69	268	78	30
TK2500	0 ~ 2500	50	3	20	16	2.6	62	43	143	25	74	285	85	50
TK3000	0 ~ 3000	50	3	20	16	2.6	62	43	143	25	74	285	85	50
TK4000	0 ~ 4000	50	4	25	22	3.5	68	43	178	35	82	338	200	100
TK5000	0 ~ 5000	100	4	25	22	3.5	68	43	178	35	82	338	200	100
TK7000	0 ~ 7000	200	4	25	22	3.5	68	43	178	35	82	338	205	100
TK10000	0 ~ 10000	200	4	25	22	3.5	68	43	178	35	82	338	205	100
TK15000	0 ~ 15000	200	8	35	32	7	95	83	230	35	145	493	600	250
TK20000	0 ~ 20000	200	8	35	32	7	118	83	280	35	140	538	680	250
TK30000	0 ~ 30000	500	8	40	38	7	130	83	305	35	172	595	830	350

Model (cN)	Range (cN)	Incr. (cN)	A mm	B mm	C mm	D mm	E mm	F mm	G mm	H mm	I mm	L mm	Weight (g)	Correcting value for horizontal measurements (cN)
TK10cN	0 ~ 10	0.5	1.5	16	13	1.5	40	19	98	15	48	180	30	3
TK30cN	0 ~ 30	1	1.5	16	13	1.5	60	19	113	15	66	213	30	3
TK50cN	0 ~ 50	1	1.5	16	13	1.5	60	19	113	15	66	213	30	3
TK110cN	0 ~ 110	2	2	16	13	2	60	27.5	113	15	65.5	221	35	10
TK200cN	0 ~ 200	5	2	16	13	2	60	27.5	113	15	65.5	221	35	10
TK300cN	0 ~ 300	5	2	16	13	2	60	27.5	113	15	65.5	221	35	10
TK500cN	0 ~ 500	10	3	20	16	2.6	56	43	131	25	69	268	78	30
TK600cN	0 ~ 600	20	3	20	16	2.6	56	43	131	25	69	268	78	30
TK1000cN	0 ~ 1000	25	3	20	16	2.6	56	43	131	25	69	268	78	30
TK1500cN	0 ~ 1500	50	3	20	16	2.6	56	43	131	25	69	268	78	30
TK2000cN	0 ~ 2000	50	3	20	16	2.6	56	43	131	25	69	268	78	30
TK2500cN	0 ~ 2500	50	3	20	16	2.6	62	43	143	25	74	285	85	50
TK3000cN	0 ~ 3000	50	3	20	16	2.6	62	43	143	25	74	285	85	50
TK4000cN	0 ~ 4000	50	4	25	22	3.5	68	43	178	35	82	338	200	100
TK5000cN	0 ~ 5000	100	4	25	22	3.5	68	43	178	35	82	338	200	100
TK7000cN	0 ~ 7000	200	4	25	22	3.5	68	43	178	35	82	338	205	100
TK10000cN	0 ~ 10000	200	4	25	22	3.5	68	43	178	35	82	338	205	100
TK15000cN	0 ~ 15000	200	8	35	32	7	95	83	230	35	145	493	600	250
TK20000cN	0 ~ 20000	200	8	35	32	7	118	83	280	35	140	538	680	250
TK30000cN	0 ~ 30000	500	8	40	38	7	130	83	305	35	172	595	830	350



- If you take a measurement horizontally, add the correcting value to the indicated measurement value per the table.



* Peak indicator is optional

- If you would like your TK gauge with a peak indicator, please specify "TK-G" on your purchase order.
 ex). TK500cN-G

DTC-REV DATA OUTPUT DIGITAL TORQUE WRENCHES

Multi Function dataout put digital torque wrench with OLED display.



FEATURES

- Accuracy : ±1% of indicated value +1 increment, over full range
- Display : OLED
- Measuring mode : ①Peak hold ②Peak to Peak ③Tracking
- Measuring direction : CW / CCW changeover, provided with CW / CCW status display
- Power supply : Lithium-ion rechargeable battery 18650 100-240V battery charger
- Battery Life : Approx. 20 hours with fully charged battery. (continuous operation)
- Auto power-off : Approx. 30 minutes
- Tolerance setting : 1 to 10%. Automatic judgment for pre-set target torque
- Data input : 1000 data can be stored

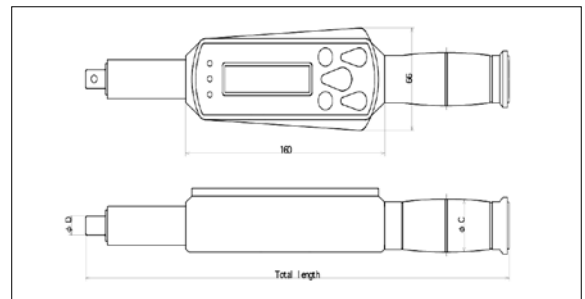

It can be measured tightening torque (CW) and loosening torque (CCW) with digital display. When the pre-set target torque is achieved, it can be confirmed with change of sounds. The preset values and tolerance can be set and the pass/fail judgment appears on LED. Data include the date (year, month, date) and time (hour, min, second) in DTC-REV. Since the OLED is high visibility, the display is easy to read even in the dark.

Model	Range(Unit)	Increment	Total length (mm)	φD.	φC	Weight (Kg)	Accessory
DTC-N10REV	1 ~ 10N·m	0.01N·m	314	10	34	0.8	12 QCK
DTC-N50REV	5 ~ 50N·m	0.01N·m	342	12	34	0.9	50 QCK
DTC-N100REV	10 ~ 100N·m	0.1N·m	386	15	34	1.1	100 QCK
DTC-N200REV	20 ~ 200N·m	0.1N·m	404	18	34	1.25	200 QCK
DTC-N300REV	30 ~ 300N·m	0.1N·m	535	22	34	1.8	280 QCK-A
DTC-N500REV	50 ~ 500N·m	0.1N·m	1063	30	34	4.2	700 QCK
DTC-N1000REV	100 ~ 1000N·m	1N·m	1417	34	34	7.6	1000 QCK
DTC-100REV	10 ~ 100kgf·cm	0.1kgf·cm	314	10	34	0.8	12 QCK
DTC-500REV	50 ~ 500kgf·cm	0.1kgf·cm	342	12	34	0.9	50 QCK
DTC-1000REV	100 ~ 1000kgf·cm	1kgf·cm	386	15	34	1.1	100 QCK
DTC-2000REV	200 ~ 2000kgf·cm	1kgf·cm	404	18	34	1.25	200 QCK
DTC-3000REV	3 ~ 30kgf·m	0.01kgf·m	535	22	34	1.8	280 QCK-A
DTC-5000REV	5 ~ 50kgf·m	0.01kgf·m	1063	30	34	4.2	700 QCK
DTC-10000REV	10 ~ 100kgf·m	0.1kgf·m	1417	34	34	7.6	1000 QCK
DTC-PI80REV	8 ~ 80lbf·in	0.01lbf·in	314	10	34	0.8	12 QCK
DTC-PI400REV	40 ~ 400lbf·in	0.1lbf·in	342	12	34	0.9	50 QCK
DTC-PI800REV	80 ~ 800lbf·in	0.1lbf·in	386	15	34	1.1	100 QCK
DTC-PF100REV	10 ~ 100lbf·ft	0.1lbf·ft	404	18	34	1.25	200 QCK
DTC-PF200REV	20 ~ 200lbf·ft	0.1lbf·ft	535	22	34	1.8	280 QCK-A
DTC-PF400REV	40 ~ 400lbf·ft	0.1lbf·ft	1063	30	34	4.2	700 QCK
DTC-PF800REV	80 ~ 800lbf·ft	1lbf·ft	1417	34	34	7.6	1000 QCK

Angle function is option: DTC-REV-A
 Bluetooth function is option: DTC-REV-B (Certified in USA, Canada, Europe, Korea, Taiwan)

DTDK-REV DATA OUTPUT DIGITAL TORQUE DRIVER

Multi Function dataout put digital torque driver with OLED display.

FEATURES

- Accuracy : $\pm 1\%$ of indicated value +1 increment, over full range
- Display : OLED
- Measuring mode : ①Peak hold ②Peak to Peak ③Tracking
- Measuring direction CW / CCW changeover, provided with : CW / CCW status display
- Power supply : Lithium-ion rechargeable battery 18650
100-240V battery charger
- Battery Life : Approx. 20 hours with fully charged battery. (continuous operation)
- Auto power-off : Approx. 30 minutes
- Tolerance setting : 1 to 10%. Automatic judgment for pre-set target torque
- Data input : 1000 data can be stored

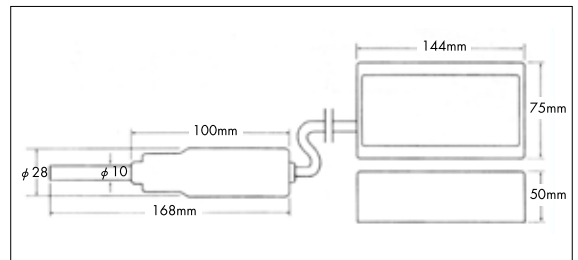

Model	Range (Unit)	Increment	Weight (kg)	Accessory
				Standard bits Phillips SB type
DTDK-CN200REV	20~200 cN·m	0.1 cN·m	1	No.0, No.1
DTDK-CN500REV	50~500 cN·m	0.1 cN·m	1	No.1, No.2
DTDK-20REV	2~20 Kgf·cm	0.01 Kgf·cm	1	No.0, No.1
DTDK-50REV	5~50 Kgf·cm	0.01 Kgf·cm	1	No.1, No.2

DTC- REV DATA OUTPUT DIGITAL TORQUE DRIVER

Separate type

DATA OUTPUT DIGITAL TORQUE DRIVER

FEATURES

- Accuracy : $\pm 1\%$ of indicated value +1 increment, over full range
- Display : OLED
- Measuring mode : ①Peak hold ②Peak to Peak ③Tracking
- Measuring direction CW / CCW changeover, provided with : CW / CCW status display
- Power supply : Lithium-ion rechargeable battery 18650
100-240V battery charger
- Battery Life : Approx. 20 hours with fully charged battery. (continuous operation)
- Auto power-off : Approx. 30 minutes
- Tolerance setting : 1 to 10%. Automatic judgment for pre-set target torque
- Data input : 1000 data can be stored

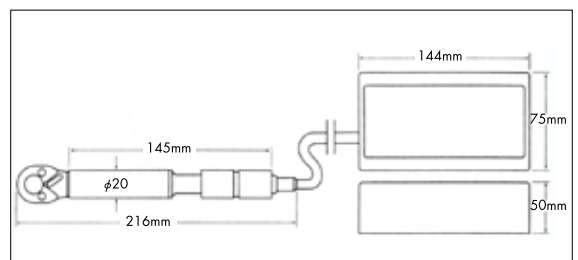

Model	Range (Unit)	Increment	Weight (kg)	Accessory
DTC-CN200REV	20~200 cN·m	0.1 cN·m	1	12QCK
DTC-CN500REV	50~500 cN·m	0.1 cN·m	1	12QCK
DTC-20REV	2~20 Kgf·cm	0.01 Kgf·cm	1	12QCK
DTC-50REV	5~50 Kgf·cm	0.01 Kgf·cm	1	12QCK

* is the new model that is applied from 1st January, 2016.

BITS

BITS FOR TORQUE DRIVERS

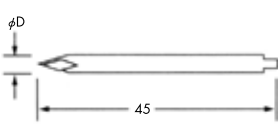
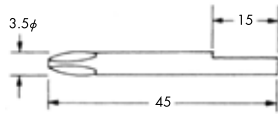
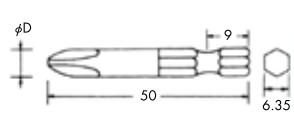
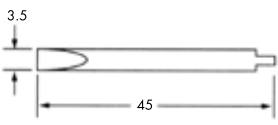
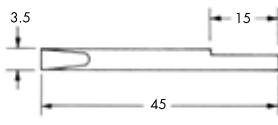
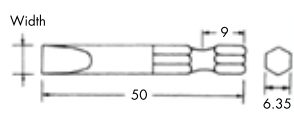
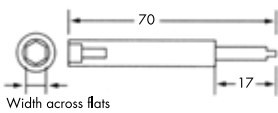
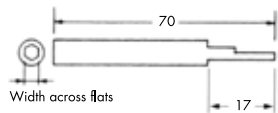
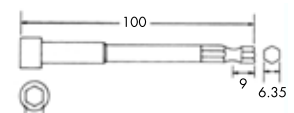
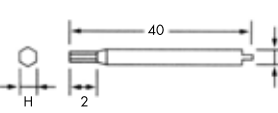
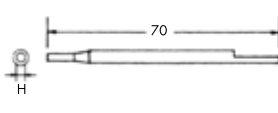
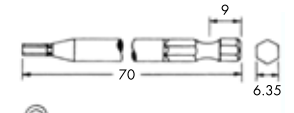
Type	CB type (KANON bits)	OB type (KANON bits)	SB type (Standard bits)																																																
Applicable driver	N1.5, 3 LTKD (N)1.5, 3STDK OI 22, 44, STDK	1.5, 3 LTKD (N) 1, 2, 5 DPSK	(N)1.5, 3 LTKD-H, (N)6, 12, 20, 30, 50, 100LTKD OI 200LTKD, PI 30, 50, LTKD (N)6, 12, 20, 30, 50, 100STDK OI 80, 200STDK, PI 20, 30, 50, 100STDK (N)10, 20, 50DPSK, (N)10, 20, 50DPSKII DTDK-20, 50EXL, DTDK-N2, NS EXL																																																
Phillips	 <p>Unit : mm</p> <table border="1"> <thead> <tr> <th>φD</th> <th>Bit sizes</th> </tr> </thead> <tbody> <tr> <td rowspan="4">3.5φ</td> <td>No.00</td> </tr> <tr> <td>No.0</td> </tr> <tr> <td>No.1</td> </tr> <tr> <td>No.2</td> </tr> </tbody> </table>	φD	Bit sizes	3.5φ	No.00	No.0	No.1	No.2	 <p>Unit : mm</p> <table border="1"> <thead> <tr> <th>φD</th> <th>Bit sizes</th> </tr> </thead> <tbody> <tr> <td rowspan="4">3.5φ</td> <td>No.00</td> </tr> <tr> <td>No.0</td> </tr> <tr> <td>No.1</td> </tr> <tr> <td>No.2</td> </tr> </tbody> </table>	φD	Bit sizes	3.5φ	No.00	No.0	No.1	No.2	 <p>Unit : mm</p> <table border="1"> <thead> <tr> <th>φD</th> <th>Bit sizes</th> </tr> </thead> <tbody> <tr> <td rowspan="2">4φ</td> <td>No.0</td> </tr> <tr> <td>No.1</td> </tr> <tr> <td>7φ</td> <td>No.2</td> </tr> <tr> <td></td> <td>No.3</td> </tr> </tbody> </table>	φD	Bit sizes	4φ	No.0	No.1	7φ	No.2		No.3																									
φD	Bit sizes																																																		
3.5φ	No.00																																																		
	No.0																																																		
	No.1																																																		
	No.2																																																		
φD	Bit sizes																																																		
3.5φ	No.00																																																		
	No.0																																																		
	No.1																																																		
	No.2																																																		
φD	Bit sizes																																																		
4φ	No.0																																																		
	No.1																																																		
7φ	No.2																																																		
	No.3																																																		
Slot Drive	 <p>Unit : mm</p> <table border="1"> <thead> <tr> <th>Blade thickness</th> <th>Width</th> </tr> </thead> <tbody> <tr> <td>0.4mm</td> <td>3.5mm</td> </tr> </tbody> </table>	Blade thickness	Width	0.4mm	3.5mm	 <p>Unit : mm</p> <table border="1"> <thead> <tr> <th>Blade thickness</th> <th>Width</th> </tr> </thead> <tbody> <tr> <td>0.4mm</td> <td>3.5mm</td> </tr> </tbody> </table>	Blade thickness	Width	0.4mm	3.5mm	 <p>Unit : mm</p> <table border="1"> <thead> <tr> <th>Blade thickness</th> <th>Width</th> </tr> </thead> <tbody> <tr> <td>0.4mm</td> <td>4.0mm</td> </tr> <tr> <td>1.0mm</td> <td>7.0mm</td> </tr> </tbody> </table>	Blade thickness	Width	0.4mm	4.0mm	1.0mm	7.0mm																																		
Blade thickness	Width																																																		
0.4mm	3.5mm																																																		
Blade thickness	Width																																																		
0.4mm	3.5mm																																																		
Blade thickness	Width																																																		
0.4mm	4.0mm																																																		
1.0mm	7.0mm																																																		
BOX BITS (Female Hex)	 <p>Unit : mm</p> <table border="1"> <thead> <tr> <th colspan="6">Width across flats</th> </tr> </thead> <tbody> <tr> <td>3</td> <td>4</td> <td>5</td> <td>5.5</td> <td>6</td> <td></td> </tr> </tbody> </table>	Width across flats						3	4	5	5.5	6		 <p>Unit : mm</p> <table border="1"> <thead> <tr> <th colspan="6">Width across flats</th> </tr> </thead> <tbody> <tr> <td>3</td> <td>4</td> <td>5</td> <td>5.5</td> <td>6</td> <td></td> </tr> </tbody> </table>	Width across flats						3	4	5	5.5	6		 <p>Unit : mm</p> <table border="1"> <thead> <tr> <th colspan="6">Width across flats</th> </tr> </thead> <tbody> <tr> <td>4</td> <td>5</td> <td>5.5</td> <td>6</td> <td>7</td> <td></td> </tr> <tr> <td>8</td> <td>9</td> <td>10</td> <td>11</td> <td>12</td> <td></td> </tr> <tr> <td>13</td> <td>14</td> <td></td> <td></td> <td></td> <td></td> </tr> </tbody> </table>	Width across flats						4	5	5.5	6	7		8	9	10	11	12		13	14				
Width across flats																																																			
3	4	5	5.5	6																																															
Width across flats																																																			
3	4	5	5.5	6																																															
Width across flats																																																			
4	5	5.5	6	7																																															
8	9	10	11	12																																															
13	14																																																		
HEX BITS (Male Hex)	 <p>Unit : mm</p> <table border="1"> <thead> <tr> <th colspan="6">Edge size (H) mm</th> </tr> </thead> <tbody> <tr> <td>1.27</td> <td>1.5</td> <td>2</td> <td>2.5</td> <td>3</td> <td></td> </tr> </tbody> </table>	Edge size (H) mm						1.27	1.5	2	2.5	3		 <p>Unit : mm</p> <table border="1"> <thead> <tr> <th colspan="6">Edge size (H) mm</th> </tr> </thead> <tbody> <tr> <td>1.27</td> <td>1.5</td> <td>2</td> <td>2.5</td> <td>3</td> <td></td> </tr> </tbody> </table>	Edge size (H) mm						1.27	1.5	2	2.5	3		 <p>Unit : mm</p> <table border="1"> <thead> <tr> <th colspan="6">Edge size (H) mm</th> </tr> </thead> <tbody> <tr> <td>1.27</td> <td>1.5</td> <td>2</td> <td>2.5</td> <td>3</td> <td></td> </tr> <tr> <td>4</td> <td>5</td> <td>6</td> <td>8</td> <td></td> <td></td> </tr> </tbody> </table>	Edge size (H) mm						1.27	1.5	2	2.5	3		4	5	6	8								
Edge size (H) mm																																																			
1.27	1.5	2	2.5	3																																															
Edge size (H) mm																																																			
1.27	1.5	2	2.5	3																																															
Edge size (H) mm																																																			
1.27	1.5	2	2.5	3																																															
4	5	6	8																																																

PARTS FOR QLK, QSPK AND QCK

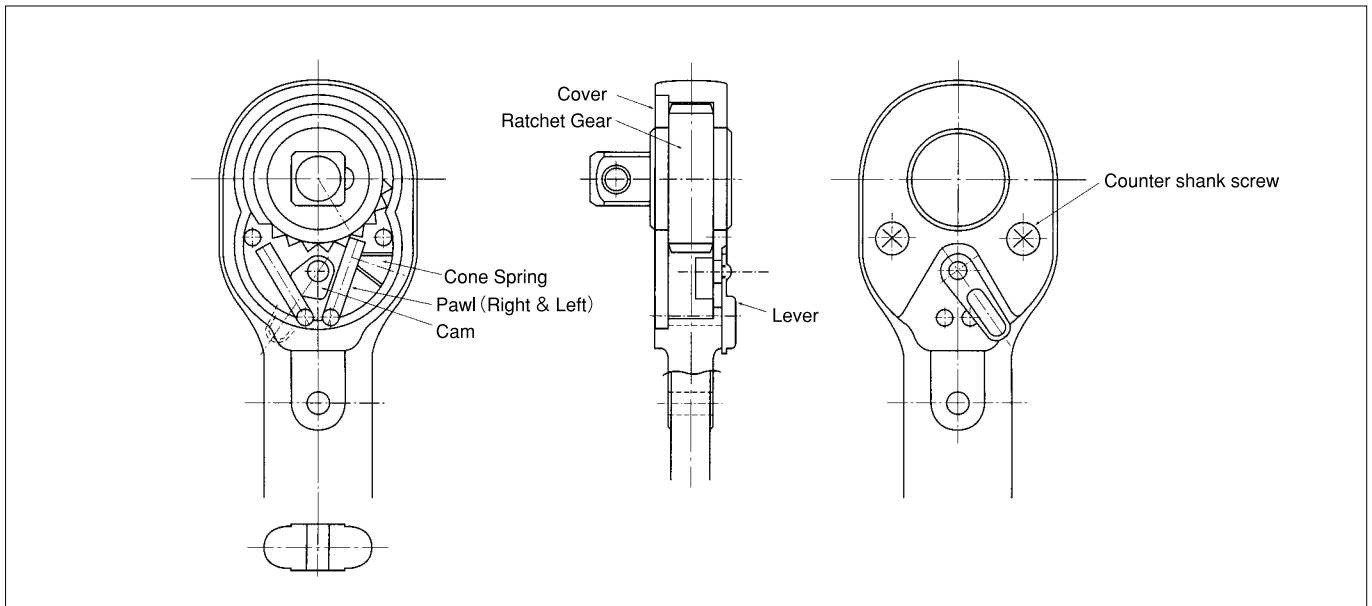

CAUTION FOR USE

CONFORM TO ITEMS AS SHOWN BELOW, AND ADEQUATELY HANDLE THE TORQUE WRENCH.

- 1 When bolts are tightened, it is dangerous to insert the pipe in the handle. Furthermore, an adequate tightening torque value can not be obtained.
- 2 If the extension tool is applied to the torque meter, a torque value indicated in the dial does not mean a torque value which is actually imposed on the bolt. (See Fig. 1)
 The torque value should be calculated as follows.

$$T = \frac{A+B}{A} \times T_1$$

Where T=force which is actually imposed on bolts.

T_1 = indication value of meter.

A = effective length of the body.

B = effective length of extension tool.

- 3 When bolts and nuts are tightened, the grasping position shall be at the center of the knurled zone, and tightening should be performed. (See Fig. 2)

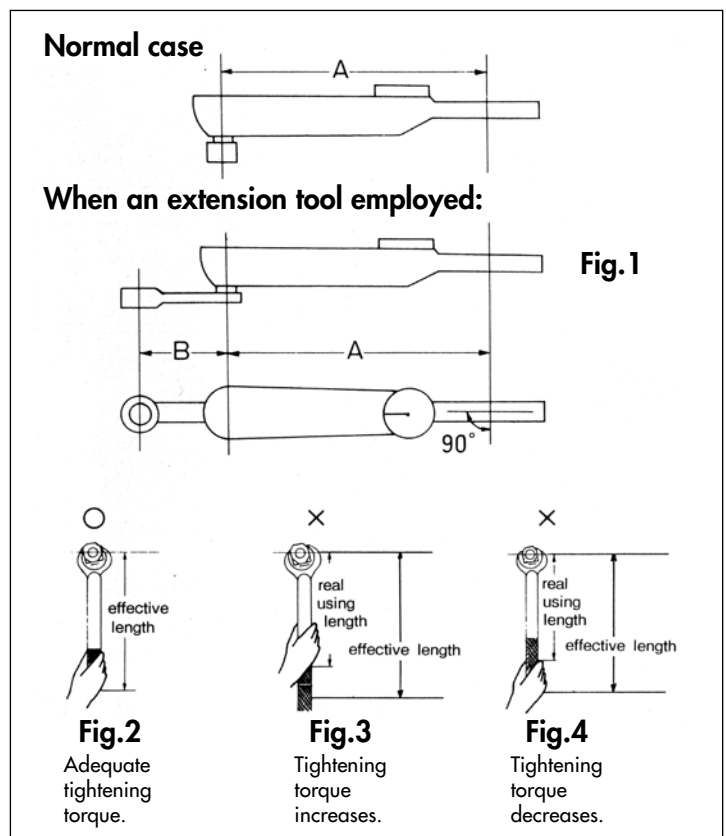

Bolt tightening torque table

Bolt width across flats (mm)			Bolt screw nominal dia.	Reference standard tightening torque $\frac{\text{kgf}\cdot\text{cm}}{\text{Nm}}$			
hexagon head bolt	set screw	hexagon socket head cap screw		Standard Bolt	7T,8T (high ten.)	10T,11T (high ten.) friction connection	Brass
4	(0.9)	(1.5)	M2	1.5 0.15	2.7 0.26	3.6 0.35	0.8 0.08
4.5	(1.27)	(2)	M2.5	3.2 0.31	5.8 0.57	7.7 0.76	1.6 0.16
5.5	1.5	2.5	M3	6 0.59	10.8 1.06	15 1.47	3 0.29
6	—	—	(M3.5)	10 0.98	18 1.77	24 2.35	5 0.49
7	2	3	M4	16 1.57	28 2.75	30 2.94	8 0.78
8	—	—	(M4.5)	21 2.06	38 3.73	50 4.9	11 1.08
8	2.5	4	M5	30 2.94	54 5.30	72 7.06	15 1.47
10	3	5	M6	50 4.9	90 8.83	120 11.77	25 2.45
11	—	—	(M7)	90 8.83	160 15.69	220 21.57	45 4.41
13	4	6	M8	120 11.77	220 21.57	290 28.44	60 5.88
17	5	8	M10	240 23.54	430 42.17	580 56.88	120 11.77
19	6	10	M12	420 41.19	760 74.53	1,000 98.07	210 20.59
22	6	12	(M14)	690 67.67	1,240 121.6	1,650 161.8	350 34.32
24	8	14	M16	1,080 105.9	2,000 196.1	2,600 255	540 52.96
27	8	14	(M18)	1,500 147.1	2,700 264.8	3,600 353	750 73.55
30	10	17	M20	2,100 205.9	3,800 372.7	5,100 500.1	1,050 103
32	—	17	(M22)	2,800 274.6	5,100 500.1	6,700 657	1,400 137.3
36	—	19	M24	3,400 333.4	6,100 598.2	8,200 804.1	1,700 166.7
41	—	19	(M27)	5,400 529.6	9,700 951.2	13,000 1,275	2,700 264.8
46	—	22	M30	7,200 706.1	13,000 1,275	17,300 1,697	3,600 353
50	—	24	(M33)	10,000 980.7	18,000 1,765	24,000 2,354	5,000 490.3
55	—	27	M36	13,000 1,275	23,400 2,295	31,200 3,060	6,500 637.4
60	—	27	(M39)	16,000 1,569	28,800 2,824	38,400 3,766	8,000 784.5
65	—	32	M42	20,000 1,961	36,000 3,531	48,000 4,707	10,000 980.7
JIS B1180	JIS B1177	JIS B1176	Related standards	SS	SCr	SCr	C-B
			Material	S-C	SCM	SCM	C-R
			Strength classify (JIS B1051)	4.6 ~ 6.9	8.8 ~ 12.9	10.9 ~ 12.9	A-B

Note: 1. The size in () of width across flats is subject to other standards than JIS.
2. Products for attached with () to the bolt and screw dia, should not be used if possible.

torque unit and conversion table

	Metric	SI unit	Imperial
Torque unit	kgf·cm kgf·m gf·cm	N·m N·cm	lbf·in lbf·ft OZf·in
Conversion in unit	1 kgf·m = 100 kgf·cm 1 kgf·cm = 1000 gf·cm 1 kgf·m = 10 kgf·mm	1 N·m = 100 N·cm	1 lbf·ft = 12 lbf·in 1 lbf·in = 16 OZf·in
Conversion between unit	1 kgf·cm = 0.098065 N·m 1 kgf·cm = 0.8679627 lbf·in 1 kgf·cm = 0.072330 lbf·ft	1 N·m = 10.1972 kgf·cm 1 N·m = 8.850 lbf·in 1 N·m = 0.737562 lbf·ft	1 lbf·in = 1.15 kgf·cm 1 lbf·in = 0.112985 N·m 1 lbf·ft = 13.825 kgf·cm 1 lbf·ft = 0.001356 N·m
Force unit	1 kgf = 9.807 N 1 kgf = 2.205 lbf	1 N = 0.101 972 kgf 1 N = 0.224809 lbf	1 lbf = 0.453592 kgf 1 lbf = 4.448 N (1 lbf = 16 OZf)
Length	1 cm = 0.393701 in	1 m = 3.281 ft	1 in = 2.54cm 1 Ft = 0.305m (1 Ft = 12 in)



Tel: 090 998 9907

Email: info@vimet.com.vn - Web: www.thietbioto.com



<http://www.bestool-kanon.co.jp>

Improvement specifications subject to change without notice.

Distributed by:

Produced by :

NAKAMURA MFG. CO., LTD.

4-4, Ohi 4-Chome, Shinagawa-ku, Tokyo 140-0014,



Tel: 090 998 9907

Email: info@vimet.com.vn - Web: www.thietbioto.com

2017.11.6000